



OPERATORS MANUAL

REACHMASTER FALCON

WARNING

Do not use the platform without reading and following the instructions carefully. Failure to comply with the correct operating procedures and safety instruction, can cause personnel injury or death.

Information

Congratulation with Your new Reachmaster Falcon.

Based upon intensive and determined product development and deep environmental awareness, combined with national and international co-operation, it is our common goal to be able to enrich our surroundings with products and service, which represent the optimum and ultimate within:

- **Technology**
- **Safety**
- **Environment**
- **Economy**
- **Quality**

Reachmaster supports all customers, national as well as international.

In case of technical and/or operational questions, please contact our Service Department,

Phone 281-358-7088

Toll Free 1-866-358-7088

E-mail service@reachmaster.com

Reporting errors

You can help to improve and correct this document. If you find any mistakes, please let us know. Mail or e-mail your observations directly to:



ReachMaster

ReachMaster Inc.

1416D Stonehollow Drive Kingwood

TX 77339 USA

E-mail: usa@reachmaster.com

Table of Contents

Information	2
Summary of WARNINGS	5
1.0 Introduction	11
1.1.01 Handling by crane	12
1.1.02 Transportation in containers	12
1.1.03 Remove ropes	12
1.1.04 Turn main switch on	12
1.1.05 Remove wooden blocks	12
1.1.06 Important	13
2.0 Supplements	14
Supplement A	15
Supplement B	16
Supplement C	23
Supplement D	23
Supplement E	24
3.0 Electrical equipment	25
3.1.01 Engaging the electrical system	26
3.1.02 Choice of control	26
3.1.03 Stability system	26
3.1.04 Controls on the platform	27
3.1.05 Charge indicator	27
3.1.06 Battery capacity Indicator	27
3.1.07 Basket rotator (Option)	27
3.1.08 Acoustic signals	28
4.0 Hydraulic equipment	29
4.1 Hydraulic equipment	30
4.1.01 Power transmission	30
4.1.02 Activation of main boom	30
4.1.03 Activating outriggers	30
4.1.04 Controls of the platform	30
4.1.05 Basket locked	30
4.1.06 Basket levelling	30
5.0 Operators Instructions	31
5.1 Driving the platform	32
5.1.01 Driving the platform	33
5.1.02 Driving the platform	35
5.1.03 Change the axle width	35
5.2 Setting up the outriggers	36
5.2.01 Setting up the outriggers	39
5.2.02 Setting up the outriggers	41
5.2.03 Setting up the outriggers	42
5.2.04 Stowing the outriggers	42
5.3 Before using the platform	43
5.3.01 Mounting the basket	43
5.3.02 Power supply	43
5.3.03 Diesel engine	43

5.4	Operating the platform	45
5.4.01	Basket Control Panel	47
5.4.02	Basket Control Panel	51
5.4.03	Chassis Control Panel	52
6.0	Emergency Lowering General	55
6.1	Electrical pump	58
6.1.01	Basket levelling	59
6.1.02	Emergency lowering Telescopes	59
6.1.03	Emergency lowering Slewing	60
6.1.04	Emergency lowering Link arm	61
6.1.05	Emergency lowering Main boom	62
6.2	Emergency lowering	63
6.2.01	Basket levelling	64
6.2.02	Emergency lowering	65
6.2.03	Emergency lowering Slewing	66
6.2.04	Emergency lowering Link arm	66
6.2.05	Emergency lowering Main boom	67
7.0	After using the platform	68
8.0	Transporting the platform	70
9.0	Safety Instructions	73
10.0	Inspection and maintenance	75
10.1	Daily inspection	76
10.2	Weekly inspection	76
10.3	Monthly inspection	76
10.4	Yearly inspection	77
10.5	Inspection and maintenance	78
10.6	Spare parts modification	80
10.7	Tightening of the crawler belts	80
10.8	Tightening of the crawler belts	81
10.9	Lubrication diagram	82
Appendix		85
Appendix A:	Sliding tracks	86
Appendix B:	Key switch at the turret	86
Appendix C:	Outriggers with hinged joints. (Option).	88
Appendix D:	Reduced working height	89
Appendix E:	Twin wheels	89

Summary of WARNINGS

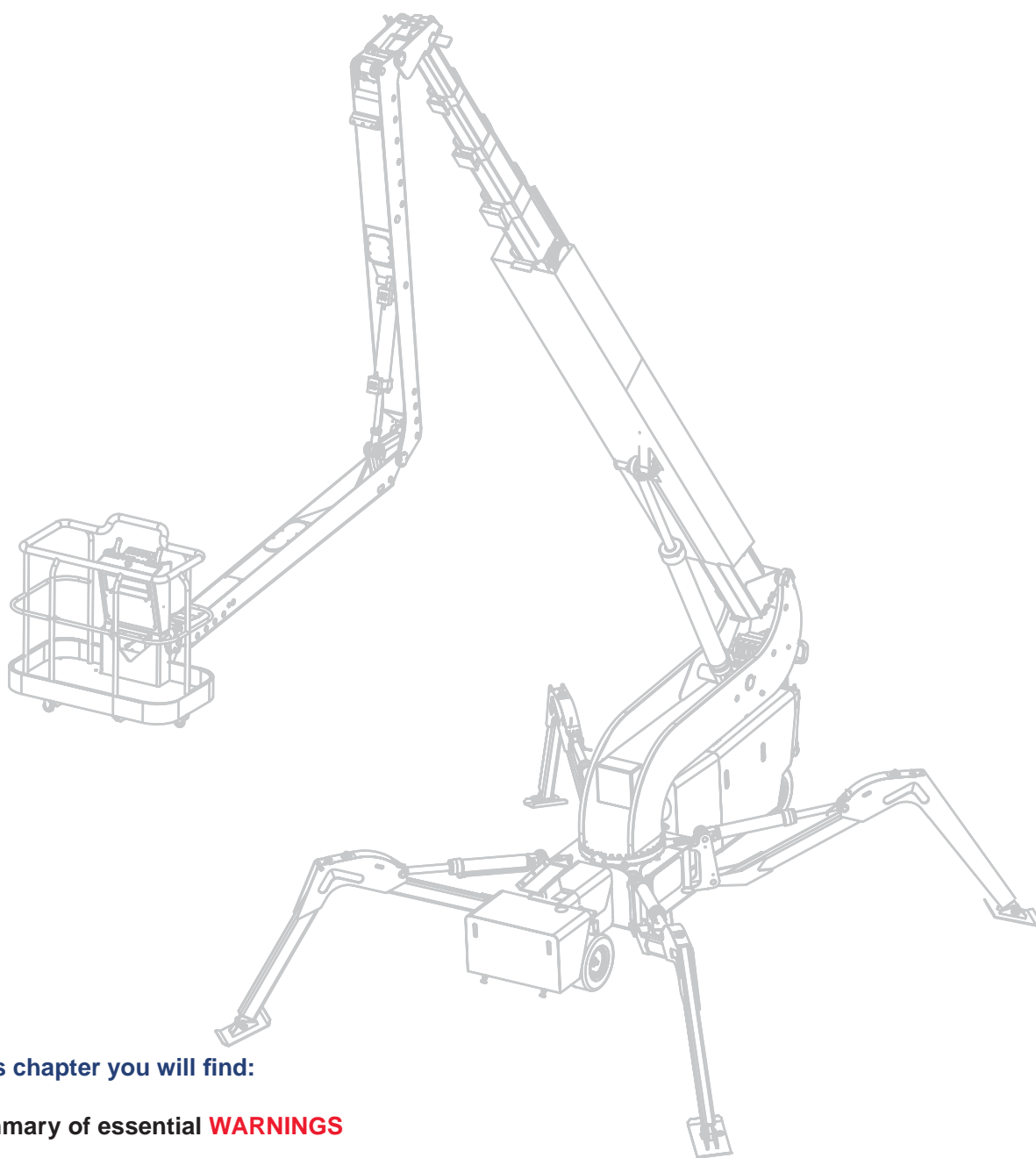

In this chapter you will find:

- Summary of essential **WARNINGS**

Summary of WARNINGS

At page:

12 WARNING

Do not attempt to open any boxes containing electrical components, when mains are connected to the machine. Contact with the main supply can cause injury or death. Before opening the boxes with electrical components, mains must be disconnected from the machine. Repair work with 24V DC power connected may only be performed by authorized personnel.

26 WARNING

Do not attempt to use the platform if **red** indicator lights at the outriggers are not ON, when the outriggers are in the stowed position or without a load. If the **red** “STABILITY” indicator lights are out when the outriggers are lifted from the ground, the safety system has a malfunction. Failure in the safety system can cause injury or death. Call an authorised service centre immediately.

30 WARNING

If a chain should break, the platform should be brought to the ground immediately. Operating the platform with a broken chain, can cause injury or death. Call an authorised service centre immediately.

30 WARNING

Follow the safety instructions carefully.

30 WARNING

When operating the platform from the ground by engaging the hydraulic valves directly the safety system is not functioning and the operator must pay highly attention to every move and follow the emergency lowering procedure. “Telescopes In” is the only function to be used until the telescopes are fully retracted. Failure to do so can cause injury or death. Call an authorised service centre immediately.

36 WARNING

When the rear axles are not locked with the locking pin, the rear axle can fall out and the platform may tip over, causing serious injury or death.

36 WARNING

When driving the platform with the axles in the stowed position, keep the platform on hard, flat ground and in low speed. If the platform is driven on a slope it can tip over and cause injury or death.

36 IMPORTANT

Use the widest axle width possible at all times.

36 WARNING

Do not attempt to drive the lift if the axles are not completely out or completely in. The platform may tip over, causing serious injury or death.

37 WARNING

Do not attempt to use the platform if the **red** lights on the outriggers or the “STABILITY” indicator lights are not ON when the outriggers are in stowed position or the outriggers are without a load. If the **red** “STABILITY” indicator lights are out when the outriggers are lifted from the ground the safety system has a malfunction. Failure in the safety system can cause injury or death. Call an authorised service centre immediately.

37 WARNING

Outrigger plates must always be mounted at the outrigger and secured **red** before attempting to lift the platform off the ground.

37 WARNING

Setting up the platform on soft ground can make the platform unstable and cause serious injury or death. Only set up the platform on hard flat ground. Load applied to the ground is given in the technical data. Setting up the outriggers – General



- 38 CAUTION**
When lowering the outriggers make sure that there is no interference with the pumps and diesel engine. Do not lower the outriggers when they are locked in the stowed position. This is not a working position and can cause interference with chassis resulting in structural damage.
- 38 WARNING**
When lowering the outriggers, do not lift the platform more than 0,6 m. from the ground. The platform does not stop automatically. Failing to do so can cause injury or death.
- 38 WARNING**
If the outrigger base of the outrigger is not locked to the chassis frame the outriggers can turn, resulting in instability which can cause injury or death. Locking bolt for securing the outrigger base to the chassis frame must always be in position before attempting to lift the platform off the ground.
- 40 WARNING**
When positioning the outriggers on the ground it is important to ensure that all limbs are kept clear of the outriggers, outrigger plates and any other moving parts. Failing to do so can cause injury or death.
- 40 WARNING**
Setting up the platform out of horizontal level to the ground can give instability and cause injury or death. The platform must be set up with chassis in horizontal level.
- 41 WARNING**
When positioning the outriggers on the ground it is important to ensure that hands, feet etc. are kept clear of the outriggers, outrigger plates and any other moving parts.
Failing to do so can cause injury or death.
- 42 WARNING**
Do not set up the platform, when the outriggers are in **Red** position (Suppl. C, Pic II) (Stowed position). This is **ONLY** transport position. Failing to do so can be a cause for injury or death.
- 43 WARNING**
When mounting the basket make sure that the basket is locked properly. A basket not locked properly can fall of and cause injury or death.
- 43 WARNING**
When the platform is used for welding work the platform has to be unplugged and the outriggers have to be placed on rubber mats.
- 45 WARNING**
The basket is not insulated for work with or near high voltage installation. Work in assured clear distance from elektrisk power lines. Failing to do so can result in electrocution causing injury or death.
- 45 WARNING**
Do not attempt to climb outside the basket when it is lifted from the ground. Always make sure you use a safety belt as required by your employer or the appropriate fall protection. Falling from the platform can cause injury or death.
- 45 WARNING**
Do not attempt to climb on top of the basket or to use a ladder or likewise from the basket.
- 45 WARNING**
Overloading the platform can cause serious injury or death. Do not overload the basket, or attempt to use the basket or the platform as a crane.
- 45 WARNING**
Before entering the basket it must be controlled that the basket is properly locked to the basket suspension. Do not attempt to use the platform without the use of a safety belt. The safety belt must be properly locked in the fixing point.
- 46 WARNING**
Always pay attention to the position of the outriggers, turret and Link-arm system while slewing. There can be danger of collision between outrigger(s) and Link-arm system and/or between the turret and outrigger(s). Failing to do so can cause structural damage to the platform.

- 46 WARNING**
When folding out the Link-arm system, make sure there is no collision between the Link-arm system and the cover(s). Raise the main boom and extend telescopes before folding out the Link-arm system. Failing to do so can cause structural damage to the platform.
- 56 WARNING**
When operating the platform from the ground, by engaging the emergency valves directly, the safety system of the platform is out of function. When operating the platform directly from the emergency valves “Telescope in” is the only function to be used. Failing to do so, can cause personnel injury or death. Call authorised maintenance immediately.
- 59 WARNING**
When activating the Emergency valves at the turret, the safety system of the platform is out of function. It is necessary to operate the platform very carefully and pay highly attention to every move. Failing to do so can cause injury or death.
- 69 CAUTION**
Do not let the basket hit the ground. This can cause structural damage to the platform.
- 69 CAUTION**
The **red** stability lights at the outriggers **MUST** come on when the outriggers are raised from the ground. Failure in the safety system can cause injury or death. Call authorised service centre immediately.
- 69 CAUTION**
When the platform is transported, the outriggers must be raised minimum 5 cm. from the ground.
- 71 CAUTION**
It is important that all 4 outriggers have the same load when loading, unloading and during operation. Notice the **red** lights on the outriggers. Always keep the platform horizontal while loading and unloading. Activate the outriggers 2 by 2, front and rear.
- 71 WARNING**
Do not set up the platform when the outriggers are in **Red** position (Stowed). This is ONLY a transport position.
- 79 WARNING**
If the **red** lights do not light up or the scale does not show allowed weight according to table column A, call an authorized service centre immediately. Failure in the safety system can result in injury or death.
- 79 WARNING**
If the scale shows more than maximum allowed weight according to table column B, call an authorized service centre immediately. Failure in the safety system can result in injury or death.
- 86 CAUTION**
Mounting of the sliding tracks with the outriggers in stowed position (Red) can cause structural damage to the platform.
- 86 WARNING**
Never use this function with wheels in narrow position, always make sure that rear wheels are set in maximum wide position before engaging this feature. Never raise the boom above 2,4 m. in this mode, measured from floor to end of main boom.
Always use maximum care when driving the unit in this position and only use it when it is absolutely necessary. As soon as surroundings permit driving the lift in normal position (secured in the cradle) lower the main boom as per below instructions.
Always take basket off before switching this mode.
Never work, place or put anybody or anything in the basket in this mode, this is strictly a transportation mode to pass obstacles on the floor that not otherwise can be passed.
- 86 WARNING**
Driving the platform with the main boom in raised position is only allowed on horizontal surface. Drive slowly and pay attention to the balance of the platform. Driving the platform on non-horizontal surfaces, can cause the platform to turn



over and result in personnel and/or material injury or death.

87 WARNING

Do NOT use any platform functions, when the key-switch is turned to the right.

Beware of basket turning!

When the main boom is lifted, the basket can be turned 90°.

When lowering the main boom and the link arm is retracted the basket will collide with the main boom. Extract the link arm to avoid collision with any part when the basket is mounted.

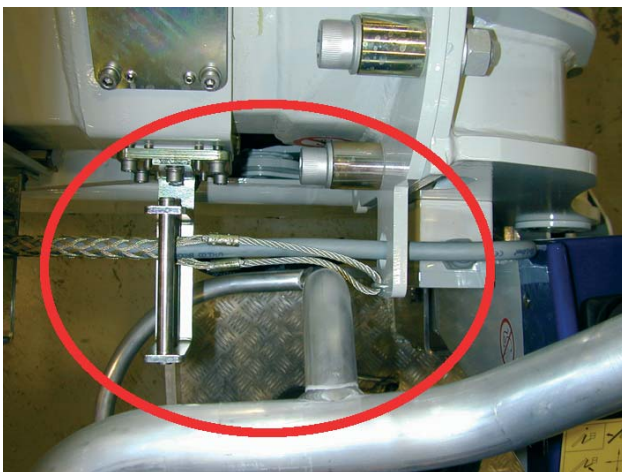
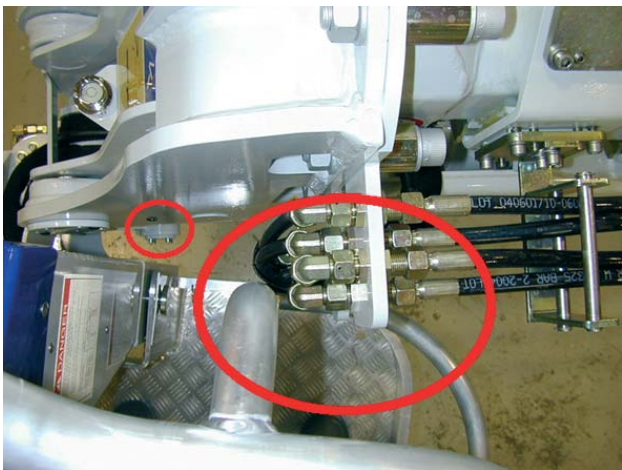
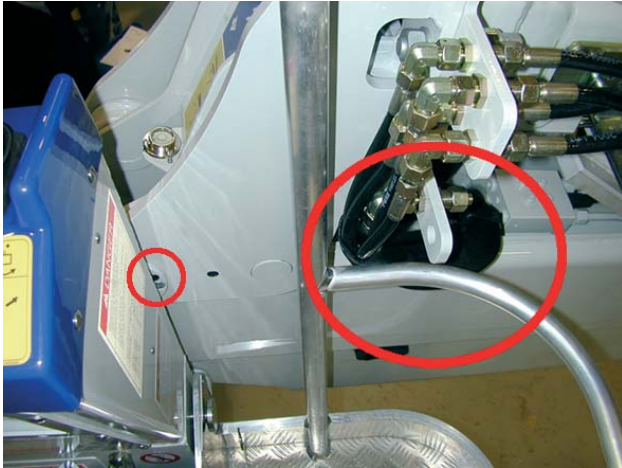

1.0 Introduction

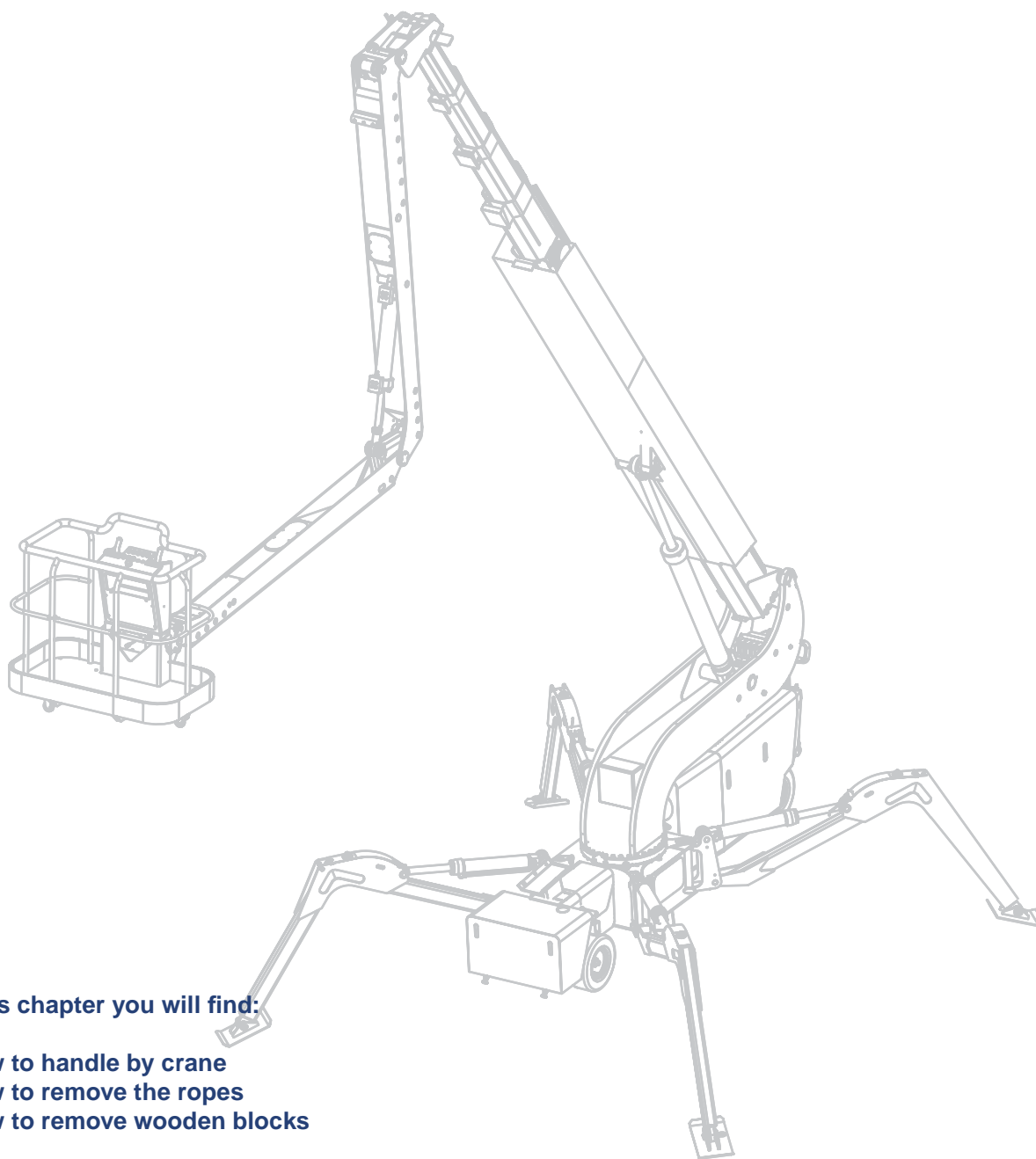

In this chapter you will find:

- **How to handle by crane**
- **How to remove the ropes**
- **How to remove wooden blocks**

1.1 Introduction

1.1.04 Turn main switch on

1.1.01 Handling by crane

If the platform is received on truck and has to be handled with crane the platform can be lifted off the truck by a crane. The outriggers shall be placed in narrow position (orange)

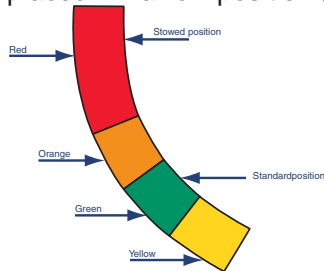

(not transport position) and the crane must be attached to the fixing points at the outriggers. Length of lifting chains on crane must be adjusted to give balance of the platform as centre of gravity is not located in the middle of the outriggers attach points.

See fig 1



Fig. 1

1.1.02 Transportation in containers

The following precautions must be observed/ noticed when receiving these machines, in the order described below. Please note that the description below is only in a short form, and that the appropriate sections of this document have to be read and followed thoroughly.

1.1.03 Remove ropes

The platform is strapped to the container with ropes etc. These ropes can be used for later strapping of the machine on a truck flatbed, etc.

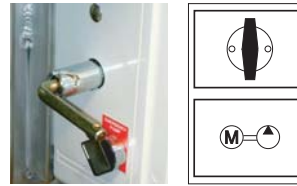

Turn on the main switch situated next to the turn switch for the emergency pump at the right side of the platform. Turn the key switch to „control from chassis“

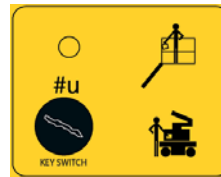

Check battery capacity indicator (round instrument) at the Chassis control panel (suppl. A) at the front of the platform.

WARNING

Do not attempt to open any boxes containing electrical components, when mains are connected to the machine. Contact with the main supply can cause injury or death.

Before opening the boxes with electrical components, mains must be disconnected from the machine. Repair work with 24V DC power connected may only be performed by authorized personnel.

1.1.05 Remove wooden blocks

The wooden blocks supporting the chassis shall be removed by the means of ordinary hand tools.

Please make sure that the upper control box does not interfere with the container roof.

1.1.06 Important

- As soon as possible, the platform must be connected to mains outlet and charged.
- Avoid leaving the platform for several days without charging.
- Use a ramp while driving the platform of the container.
- As soon as the platform has left the container set the axle width to the widest position possible.
(Not the crawler version of the Falcon platform)

2.0 Supplements

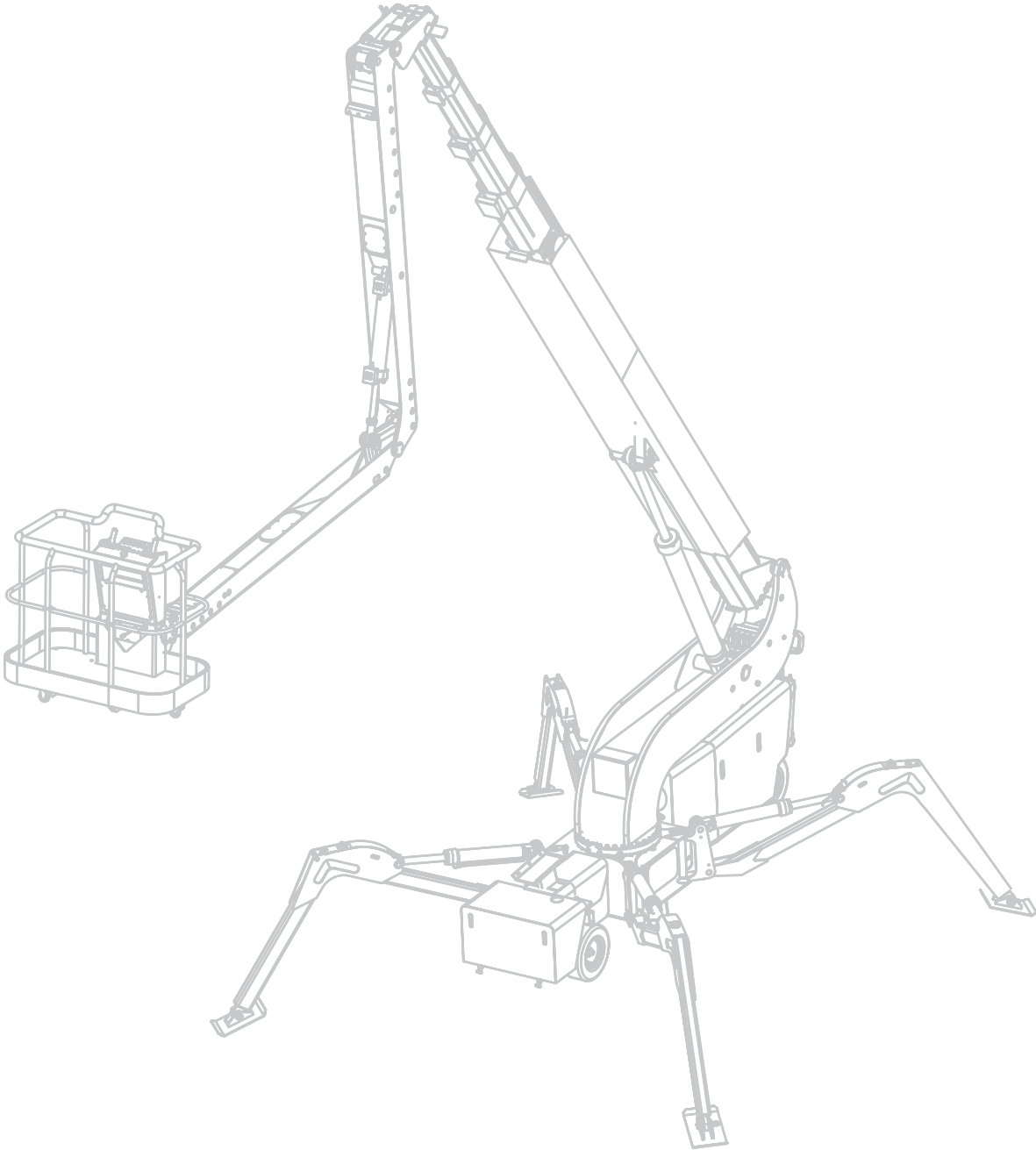

Supplement A

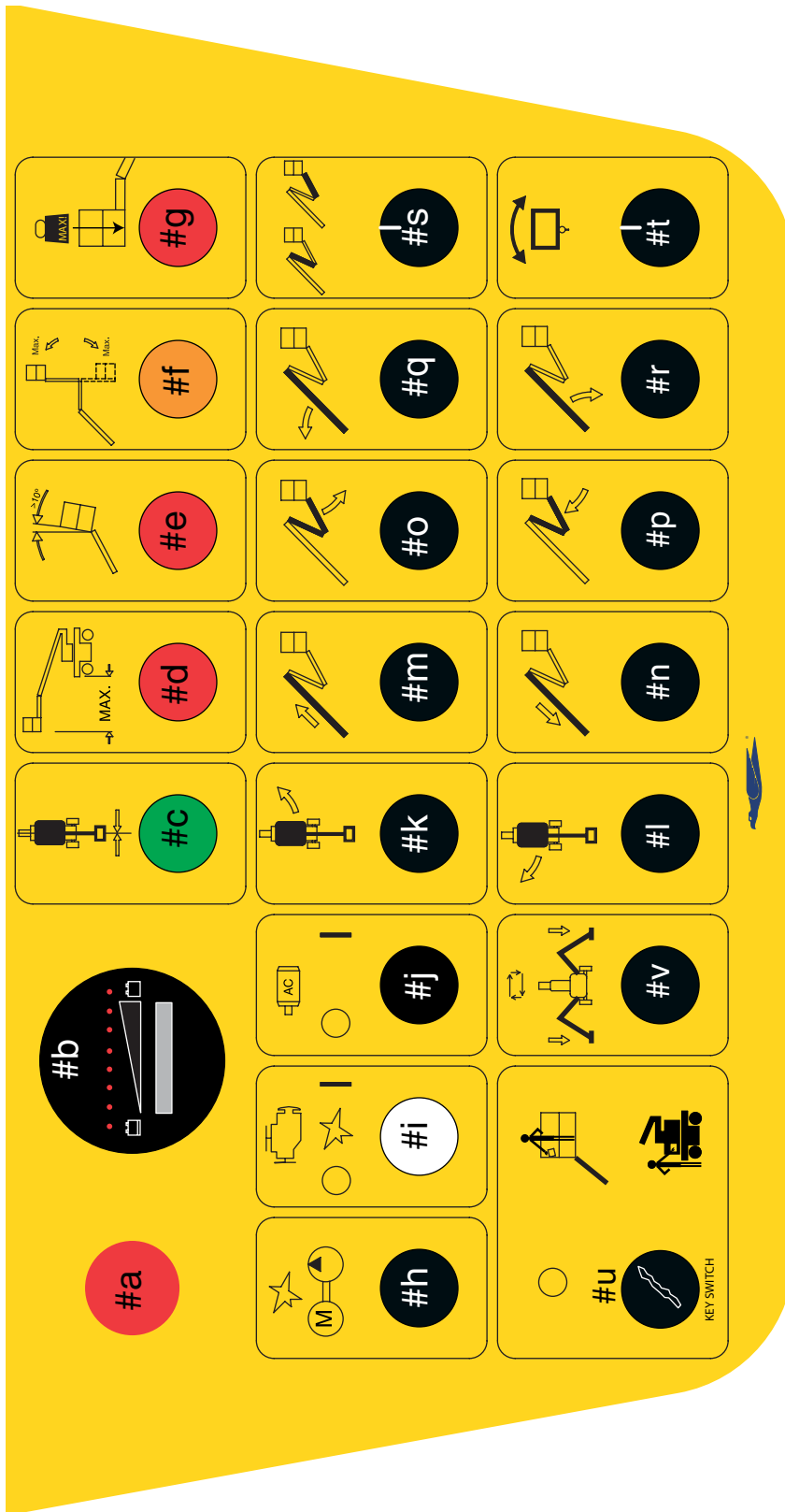

Supplement B

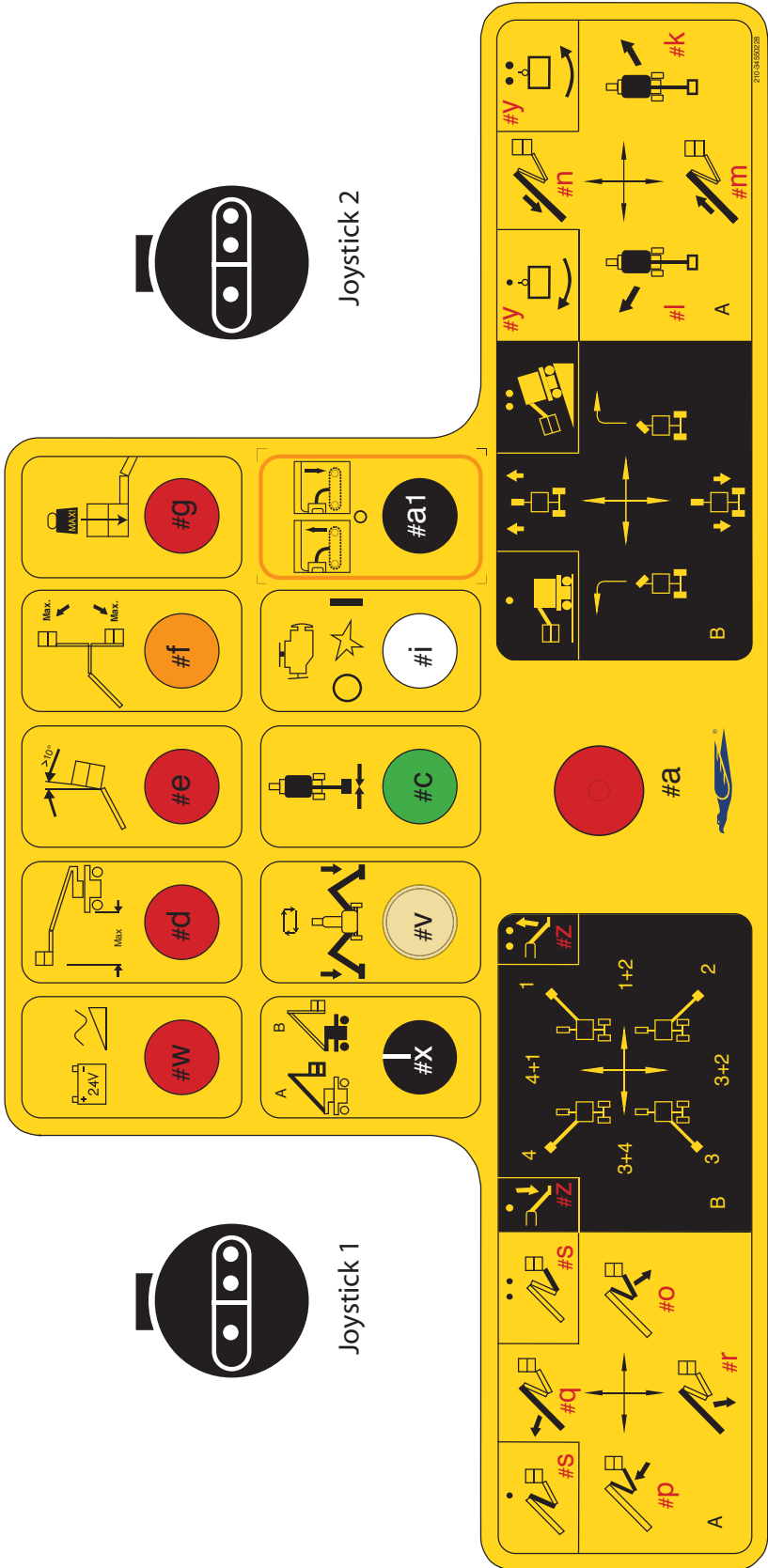

Description of the Control Panels

Chassis and Basket

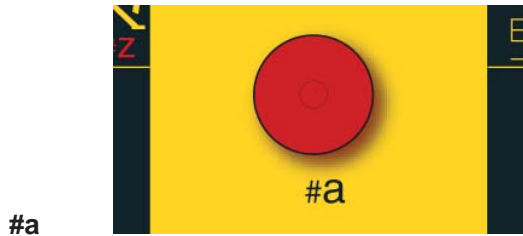

#a

EMERGENCY STOP BUTTON
Pushbutton.

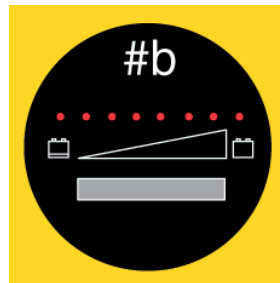

#b

BATTERY INDICATOR
It is recommended not to work with the SPIDER with battery capacity below 20%

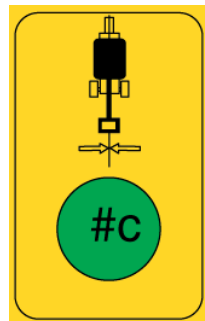

#c

INFORMATION SIGNAL
MAIN BOOM IN CENTER

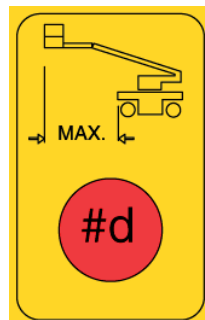

#d

WARNING SIGNAL STABILITY

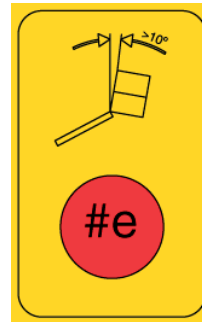

#e

WARNING SIGNAL
BASKET LOCKED

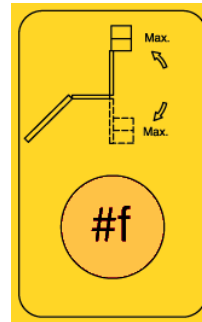

#f

CAUTION SIGNAL
MOVEMENTS BLOCKED

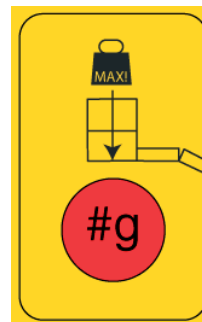

#g

WARNING SIGNAL
BASKET OVERLOAD

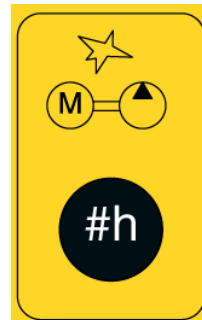

#h

PUSHBUTTON
STARTS PUMP FOR OUTRIGGERS

FOLLOWING DECALS ARE FOR THE CHASSIS CONTROL PANEL ONLY

#i

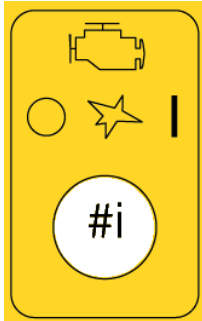

TURNABLE SWITCH FOR DIESEL ENGINE (Option)

#j

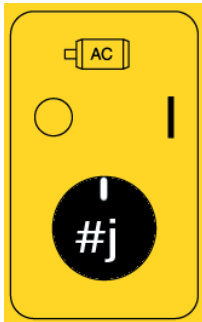

TURNABLE SWITCH 220V or 400V AC PUMP (Option)

#k

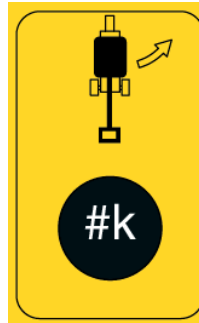

PUSHBUTTON SLEWING COUNTER-CLOCKWISE

#l

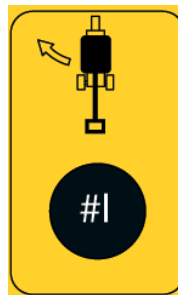

PUSHBUTTON SLEWING CLOCKWISE

#m



PUSHBUTTON EXTEND TELESCOPES

#n



PUSHBUTTON RETRACT TELESCOPES



#o



**PUSHBUTTON
MOVING LINK ARM SYSTEM**

#s

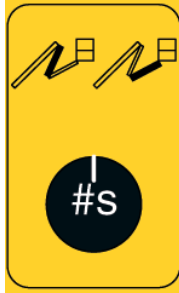

TURNABLE SWITCH

#p



**PUSH BUTTON
MOVING LINK ARM SYSTEM**

#t

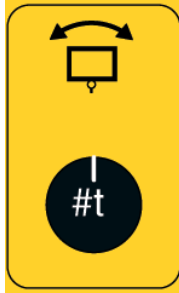

**TURNABLE SPRING LOADED
(Optional)
SWITCH FOR BASKET ROTATION**

#q



**PUSHBUTTON
MAIN BOOM UP**

#u

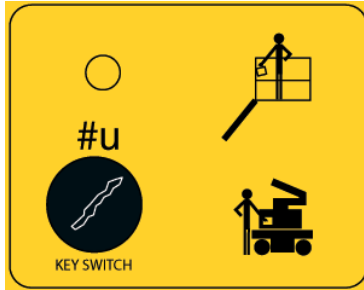

**TURNABLE KEY SWITCH
WITH 3 POSITIONS**

#r



**PUSH BUTTON
MOVING MAINBOOM DOWN**

O = Off

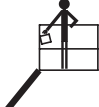
 = Operate the SPIDER from the control panel in the basket.

 = Operate the SPIDER from the chassis control panel.

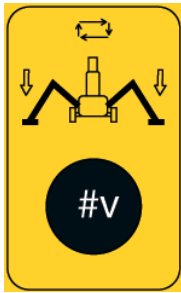

#v

**PUSHBUTTON
OUTRIGGER SET UP**

**THESE INFORMATIONS ARE FOR THE
BASKET CONTROL PANEL ONLY!**

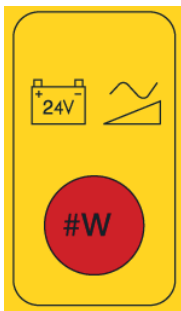

#w

**CAUTION SIGNAL
LOW BATTERY CAPACITY**



#x

TURNABLE SWITCH

#a1

**THIS IS ONLY FOR CRAWLER
PLATFORMS TALLER THAN 32
METERS/105 FEET.**



Choose for front track unit
Choose between raising or lowering
the front belts from the ground during
operation it its possible to control the the
platforms free height.
Especially needed when working in
uneven terrain.



#y

**PICTOGRAM FOR THE SELECTOR
SWITCH.**

(Top of left joystick)
When using the platform functions
choose between Basket rotation
clockwise or counter-clockwise.
By pressing the selector switch to the
left, marked with a dot • the basket
rotation will be clockwise. By pressing
the selector switch to the right, marked
with two dots •• the basket rotation will
be counter-clockwise.
To stop the basket rotation release the
selector switch.



#z

**PICTOGRAM FOR THE TOP OF THE
LEFT JOYSTICK**

By pressing the selector-switch marked
with a dot • continously the outrigger(s)
will move down when using one of the
outrigger functions.
By pressing the selector-switch marked
with two dots •• continously the outrigger(s)
will move up when using one of the
outrigger functions.
Outrigger functions:

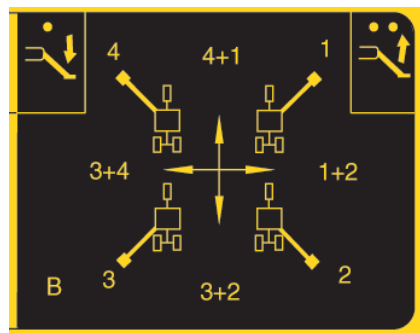

Control of the outriggers. Complete
pictogram.



Movement of Outrigger 1.

By moving the joystick up diagonal to the right, **Outrigger 1** moves up or down depending on position (1 or 2) of the selector switch at the top of the left joystick.



Movements for Outrigger 1&2.

By moving the joystick to the right Outrigger 1&2 move up or down depending on position (1 or 2) of the selector switch at the top of the left joystick.



Movements for Outrigger 2.

By moving the joystick down diagonal to the right, **Outrigger 2** moves up or down depending on position (1 or 2) of the selector switch at the top of the left joystick.

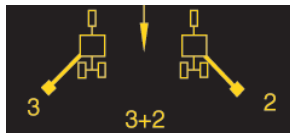

Movements for Outrigger 3&2.

By moving the joystick down, **Outrigger 3&2** move up or down depending on position (1 or 2) of the selector switch at the top of the left joystick.

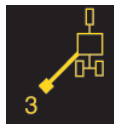

Movements for Outrigger 3.

By moving the joystick down diagonal to the left, **Outrigger 3** moves up or down depending on position (1 or 2) of the selector switch at the top of the left joystick.



Movements for Outrigger 3&4.

By moving the joystick to the left **Outrigger 3&4** move up or down depending on position (1 or 2) of the selector switch at the top of the left joystick.



Movements for Outrigger 4.

By moving the joystick up diagonal to the left, **Outrigger 4** moves up or down depending on position (1 or 2) of the selector switch at the top of the left joystick.



Movements for Outrigger 4&1.

By moving the joystick up, **Outrigger 4&1** move up or down depending on position (1 or 2) of the selector switch at the top of the left joystick.

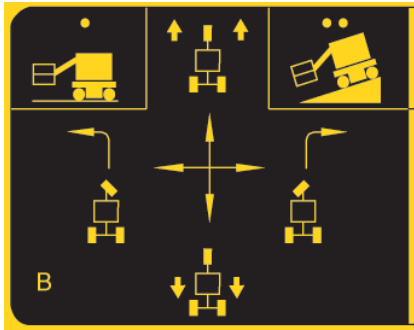

Complete pictogram for driving.



Pictogram (Horizontal surface).

Left side of the pushbutton at the top of the joystick marked with 1 dot • is left side of the push button pushed down. Low traction (Higher speed) are selected.



Pictogram (Surface with gradient)

Right side of the pushbutton in the top of the joystick marked with 2 dots •• is right side of the push button pushed down. High traction (Lower speed) are selected.



When the front tracks or wheels are turned, and the operator lets go of the joystick, the front tracks/wheels will not automatically go back to middle position. The front tracks/wheels will stay in the turned position until it is turned in the opposite direction. By moving the joystick up to the right, the platform turns CW and drives away from the operator at the same time.



By moving the joystick down to the left, the platform will turn CW and drive against the operator at the same time. By moving the joystick up to the left, the platform turns CCW and drive away from the operator at the same time.

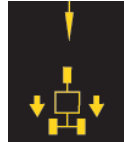

Driving backwards.

By pulling the joystick the platform will drive against the operator.



Driving forwards.

By pushing the joystick up the platform will drive in the direction away from the operator.



Supplement C



Pic. I
Battery Main Switch

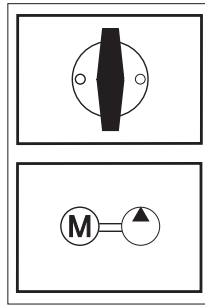

Supplement D

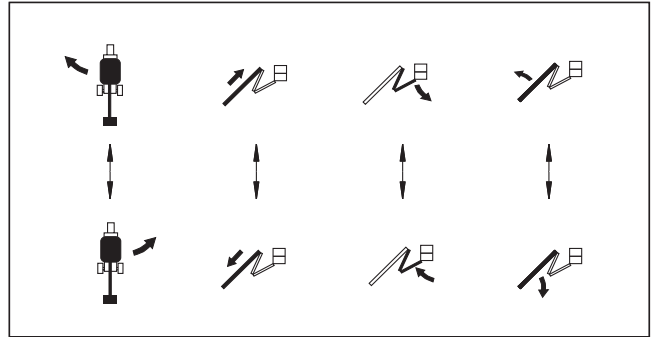

Decal for Emergency lowering at turret



Pic. II
Outrigger Indicator



Pic. III
Emergency kit with standard handle (green frame = for track version)



Pic. IV
Emergency tools

Supplement E

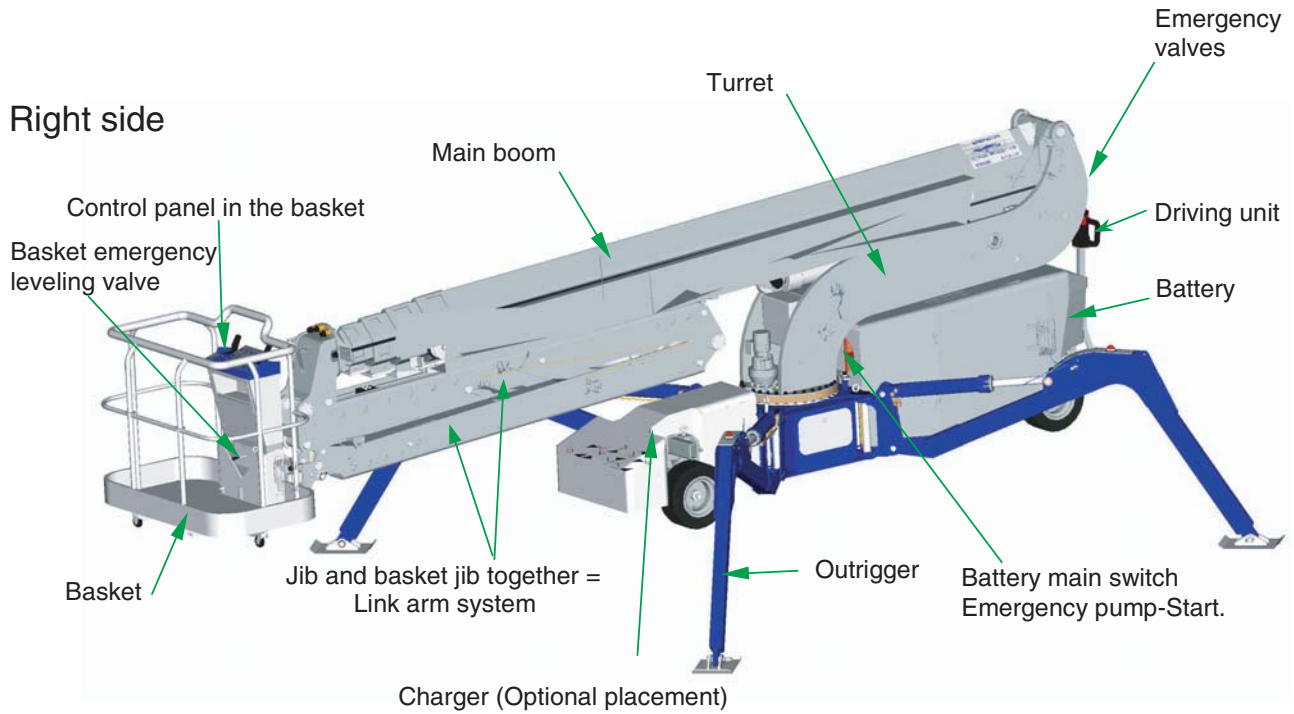

Left side

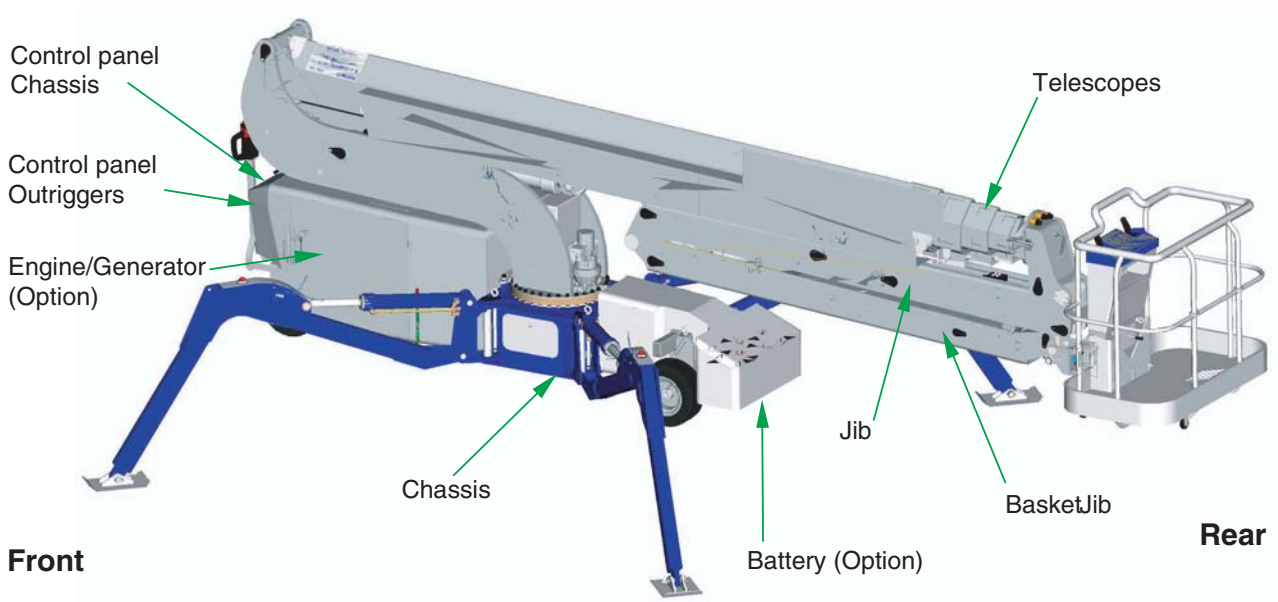

3.0 Electrical equipment

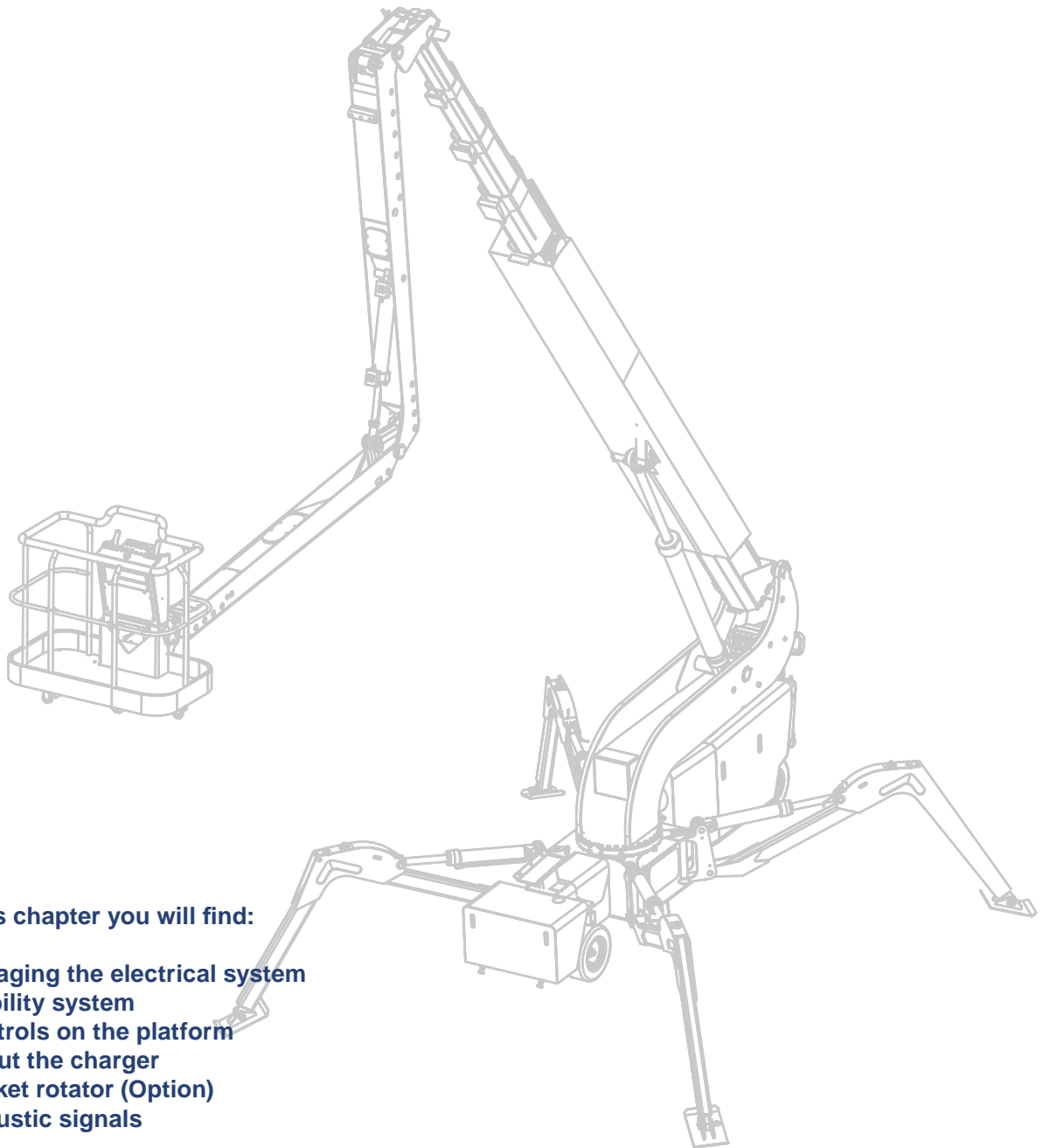

In this chapter you will find:

- **Engaging the electrical system**
- **Stability system**
- **Controls on the platform**
- **About the charger**
- **Basket rotator (Option)**
- **Acoustic signals**

WARNING

Do not attempt to open any boxes containing electrical components when power is connected to the machine. The mains supply can cause injury or death. Before opening the boxes containing electrical components the mains must be disconnected from the machine. Repair work with 24V DC power connected may only be performed by authorised personnel.

3.1.01 Engaging the electrical system

The platform is equipped with a main switch, which is located at the right side of the platform, next to the switch for the emergency pump.

Turn the main switch to position “ON”.

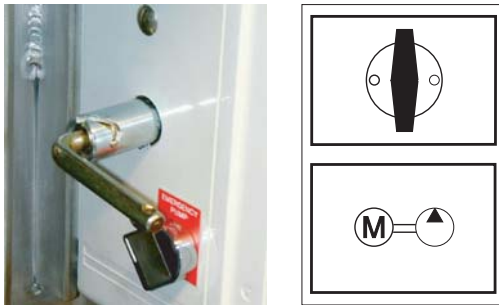
**3.1.02 Choice of control**

The platform can be operated from the Chassis control panel (suppl. A) or from the control panel in the basket (suppl. B).

The key switch (#p) for choice of control panel is located at the Chassis control panel (suppl. A).

Remove the key to prevent unauthorised use of the platform.

When the key switch (#p) is in position O, the platform is turned off.

By turning the main switch to position,

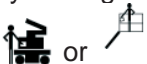

the red indicator lights on the outriggers shall light up when the outriggers are in stowed position or without a load. Always check the red indicator lights (Stability system) at the outriggers before starting to work.

WARNING

Do not attempt to use the platform if red indicator lights at the outriggers are not ON, when the outriggers are in the stowed position or without a load.

If the red “STABILITY” indicator lights are out when the outriggers are lifted from the ground, the safety system has a malfunction.

Failure in the safety system can cause injury or death.

Call an authorised service centre immediately.

3.1.03 Stability system

The platform is equipped with an automatic system by which mechanical/electrical measurement secures that the platform always has the minimum required stability.

If the minimum required stability is reached the platform automatically “CUTS OUT” the functions that would reduce the stability further. During minimum stability:

“CUT OUT” the red indicator light at the outriggers with minimum pressure, will come on and the red indicator light “STABILITY” at the Basket control panel (Suppl. B) and at the Chassis control panel (suppl. A) will also come on.

If only the red indicator light “STABILITY” at the Basket control panel (Suppl. B) and at the Chassis control panel (suppl. A) comes on, a secondary “CUT OUT” stability system is activated and notices deflection of the main boom.

The only functions that are free during “CUT OUT” and secondary “CUT OUT” will be:

**RETRACT TELESCOPE
MAIN BOOM UP**

These functions will increase the stability.

WARNING

Do not attempt to use the platform if red indicator lights at the outriggers are not ON, when the outriggers are in the stowed position or without a load.

If the red “STABILITY” indicator lights are out when the outriggers are lifted from the ground, the safety system has a malfunction.

Failure in the safety system can cause injury or death.

Call an authorised service centre immediately. injury or death.

Call an authorised service centre immediately.

3.1.04 Controls on the platform (Movements and outriggers)

Chassis control panel (suppl. A)– Active:

By turning the key switch (#u) at the control panel to Position Chassis  the Chassis control panel (suppl. A) is active, and can control the movement of the main boom, telescopes, slewing, jib and basket jib by the push button.

The outriggers are controlled by hydraulic valves, activated by the control handles marked 1, 2, 3, and 4 according to the outriggers numbers, located under the chassis control panel – Outriggers at the front of the platform.

Driving the platform are done by the driving unit or the portable control box.

Control panel in the basket – Active:

By turning the key switch (#u) at the control panel to position Basket 

The Basket control panel (Suppl. B) is active, and controls movement of the main boom, telescopes, slewing, jib and basket jib, and as option, outriggers and driving functions by the joysticks and selector switches.

3.1.05 Charge indicator

On the charging box, under the cover in the rear end, you'll find small lights (LED).

When the charger is connected to the mains, the “ON” LED will flash for about 5 seconds. In these first 5 seconds the charger reads all input signals and calculates the necessary output voltage. After 5 seconds the charger will switch on, and the “ON” LED illuminates.

There are also LEDs for the following functions

- Charge voltage
- Charge current
- Boost
- Equalise
- Float charge
- Failure

3.1.06 Battery capacity Indicator (Supplement A, #b)

The battery capacity indicator is located at the Chassis control panel (suppl. A).

The battery capacity indicator displays the capacity of the battery system in 9 levels of capacity, which are indicated by digital steps (Yellow lights).

When the capacity is below 50%, the remaining 3 yellow lights and an indicator light at the Basket control panel (Suppl. B), shines continuously, to indicate the capacity of the battery system is low. It is important to charge the battery system now.

One yellow light for every 10% capacity.

Red light indicates capacity below 20%.

CAUTION

Do not operate the platform if capacity is below 20%.

After long distance travelling you must secure that there is enough capacity to work with the platform, otherwise you must recharge the battery.

3.1.07 Basket rotator (Option)

The platform can as optional be equipped with a basket rotator, which can be controlled by the Basket control panel (Suppl. B) and from the Chassis control panel (suppl. A).

3.1.08 Acoustic signals

The platform is equipped with an acoustic pulsing signal when using the chassis functions (Driving and outriggers functions).

A slope alarm gives an increasing pulsing acoustic signal, when the chassis reach a dangerous angle (There is danger that the platform will turn over) according to horizontal.



4.0 Hydraulic equipment

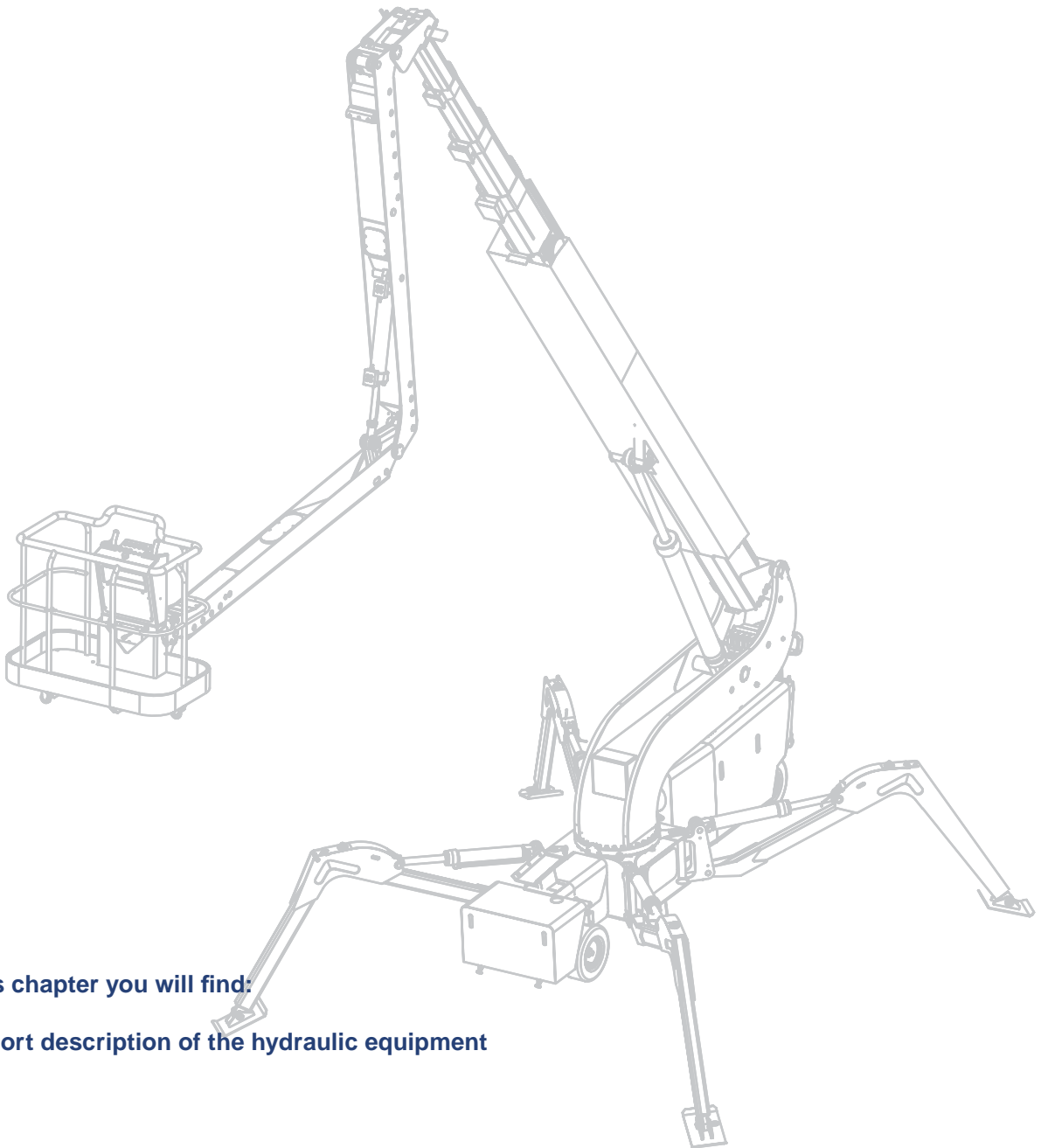

In this chapter you will find:

- **A short description of the hydraulic equipment**

4.1 Hydraulic equipment

4.1.01 Power transmission

The platform is equipped with an oil pump which is driven of the 24V DC motor.

Furthermore proportional valves, filters and the oil tank in the turret section enables power transmission and a hydraulic oil pump driven by a diesel engine.

4.1.02 Activation of main boom Telescopes, jib, basket jib and basket rotator

Movements of main boom and link arm system are done by hydraulic cylinders. Telescoping is done by hydraulic cylinders and a chain system.

A hydraulic actuator does the movement of the basket rotator (Optional).

WARNING

If a chain is too slack, the platform should be brought to the ground immediately. Operating the platform with a broken chain, can cause injury or death. Call an authorised service centre immediately.

4.1.03 Activating outriggers

4 pcs. hydraulic cylinders provide movements of the outriggers (Vertical).
The cylinders have safety valves.

4.1.04 Controls of the platform

The platform can be operated from the Chassis control panel (suppl. A) located at the front of the platform or from the Basket control panel (Suppl. B).

A turnable key switch located at the Chassis control panel (suppl. A, #u), does the selection of control panel.

4.1.05 Basket locked

If the basket tilts more than 10° it will automatically secure its position. If possible move the main boom or the Link arm system in the opposite direction, until the basket is back at horizontal level.

4.1.06 Basket levelling

The basket is levelled by a hydraulic/electronic levelling system supplied from a separate 24 V DC oil pump.

WARNING

Follow the safety instructions carefully.

4.1.07 Emergency lowering

In case of electrical fault or in emergency situations the platform can be operated manually by the emergency (hydraulic) valves located at the turret.

WARNING

When operating the platform from the ground by engaging the hydraulic valves directly the safety system is not functioning and the operator must pay highly attention to every move and follow the emergency lowering procedure. "Telescopes In" is the only function to be used until the telescopes are fully retracted. Failure to do so can cause injury or death. Call an authorised service centre immediately.



5.0 Operators Instructions

In this chapter you will find:

- Operators Instructions
- Driving the platform Self-propelled with driving unit
Wheel Models until 32 meter
Sections marked blue
- Driving the platform Self-propelled with portable box
Crawler Models and wheel models taller than 32 meter
Sections marked green
- Driving the platform from the transportable driving unit
- Setting up the outriggers from Chassis control panel
- Setting up the outriggers from the Basket control panel
- Setting up outriggers automatically (Option)
- Stowing the outriggers
- Mounting the basket
- About the diesel engine
- Operating the platform
- Joystick description
- Basket control panel Description
- Chassis control panel Description

5.1 Driving the platform Self-propelled drive

(Portable box)

For crawler models and wheel models taller than 32 meter/105 feet.

The platform is self-propelled by a driving unit which means that it can be moved to a job site and back.

The platform can be driven from the ground by a Transportable driving unit placed at the front of the platform or from the right joystick at the Basket control panel (Suppl. B) (Joystick 2)



Fig. 4 Portable driving box

Driving the platform self-propelled drive (Driving unit)

For wheel models until 32 meter



fig. 3 Driving unit

The platform can be driven from the ground, by the driving handle at the front of the platform or as option, from the right joystick at the Basket control panel (Suppl. B) (Joystick 2).

All:

The driving unit have two control facilities (Speed values):



The default value

The platform drives fast, but with a low traction.



The platform drives slowly, but with maximum traction.

For driving the platform on surfaces with a gradient > 5°

Option for track models taller than 32m/105ft:

Differential blocking system for tracks.

The tracks are equipped with a hydraulic differential system to make it easier to turn in very uneven terrain which could make the tracks spin.

When the buttons 1 or 2 is selected for more than 1,5 sec. the differential blocking is activated and all tracks are driving.

The platform is equipped with an acoustic pulsing signal.

When using the chassis functions (driving and outrigger functions) a slope alarm gives a quick pulsing acoustic signal, if the chassis reaches a dangerous angle (If the danger is that the platform will turn over).

Before using the chassis functions (Driving and outrigger functions):

Retract the telescopes completely

Folding in the link arm

Main boom in centre (the green information signal (Suppl. A + B, #c) at the control panels comes on.)

Main boom down

5.1.01 Driving the platform

1. Make sure that the main switch (Located on the side of the platform next to the emergency pump) is in position **ON**
2. Turn the key switch (#u) on the Chassis control panel (suppl. A) to position  Chassis.
3. The platform can now be driven from the driving handle (fig. 3 wheel models until 32 meter) or from the joystick at the transportable driving unit (fig. 4 crawler models and wheel models taller than 32 meter.). It is recommended that the operator wears the belts of the portable driving box.

A: From portable box (Crawler models and wheel models taller than 32 meter/105 feet)

Chose traction (Speed • or •• Optional), at the push button at the top of the joystick. The chosen value is the active value when the operator lets go of the button until another choice is made.

The platform is driven from the joystick. The joystick is one-hand controlled by a trigger which means the operator must push the trigger continuously when activating one of the driving functions.



Fig. 6 Joy-stick at the portable control box

The transportable driving units equipped with an emergency stop button. By pushing the emergency stop button all functions of the platform will stop (Chassis and platform functions). To deactivate the emergency stop button, turn the button and it will automatically deactivate

The driving functions according to the label below.

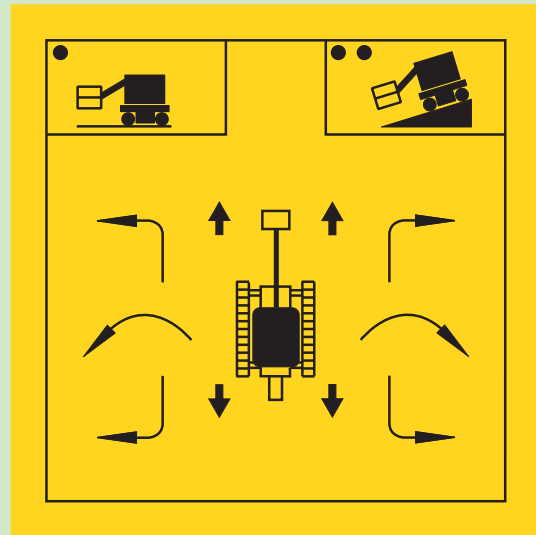

For crawler versions

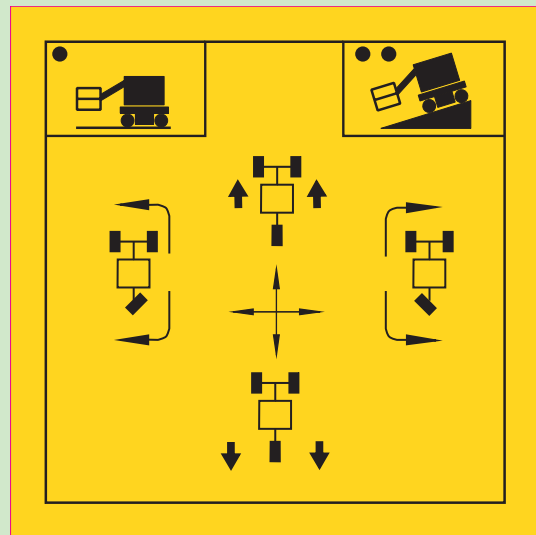

For wheel versions taller than 32 meter

Descriptions of the driving functions according to the label at the Portable driving box
The operator must stand in front of the platform facing the front of the platform

If the operator lets go of the joystick it will automatically return to middle position and the function stops.

CW = Clock wise
CCW = Counter clock wise

1. Pictogram (Horizontal surface) at the left side of the push button in the top of the joystick marked with 1 dot •

If the left side of the push button is pushed down low traction (Higher speed) is selected.

2. By moving the joystick up, backward driving is selected and the platform will drive away from the operator.

3. Pictogram (Surface with gradient) at the right side of the push button in the top of the joystick, marked with 2 dots ••
If right side of the push button is pushed down high traction (Lower speed — with blocking) is selected.

4. By moving the joystick up to the right, the platform turns CW and drives away from the operator at the same time.

5. By moving the joystick to the right, the front tracks will turn/rotate CCW

Track models until 32 meter.

By moving the joystick to the right, the tracks will turn/rotate CW

6. By moving the joystick down to the right, the platform turns CCW and drive against the operator at the same time.

7. By moving the joystick down, forward driving is selected and the platform will drive against the operator.

8. By moving the joystick down to the left, the platform will turns CW and drive against the operator at the same time.

9. By moving the joystick to the left, the front tracks will turn/rotate CW.

Track models until 32 meter.

By moving the joystick to the left, the tracks will turn/rotate CCW.

10. By moving the joystick up to the left, the platform turns CW and drive away from the operator at the same time.

B: From driving handle

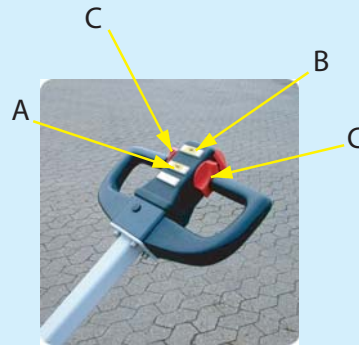

The SPIDER can be driven by the driving handle located at the front of the SPIDER.

Select the speed value 

or optional  by the push buttons.

By moving the speed controllers (C) away from the operator, backward driving is selected and the platform will drive away from the operator.

By moving the speed controllers (C) towards the operator forward driving is selected and the platform will drive against the operator.

- A. Button for single wheel drive
- B. Button for 2-wheel drive (Option)
- C. Proportional speed controller

**5.1.02 Driving the platform
Self-propelled drive from the
Basket control panel (Suppl. B)
(Option at wheel models)**

1. Make sure the main switch (Located at the side of the platform next to the emergency pump) is in position ON.
2. Turn the key switch (#u) at the Chassis control panel (suppl. A) to position Basket 
3. Enter the basket (Max. 200 kg)
4. Turn the selector switch (#x) at the Basket control panel (Suppl. B) to position B for chassis functions.

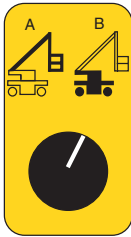

Fig. 7

5. Drive the platform by the right joystick according to the label below.

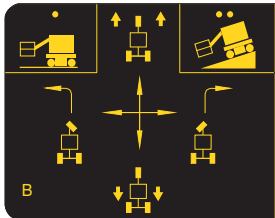

Fig. 8

The joystick is equipped with a selector switch in the top marked with 1 dot in the left side for low traction (default value) and 2 dots in the right side for high traction (Option). The platform will keep the selected value until the selector switch is engaged again.

The joystick is equipped with one hand control (A trigger, press it when activating the joystick). To drive the platform forward push the joystick. To drive backwards pull the joystick. To turn see section 5.1.01 for detailed driving. It is possible to turn the front track/wheel and drive the platform at the same time. All movements of the platform are proportional.

5.1.03 Change the axle width

Wheel models until 32 meter

The axle width of the rear set of wheels is adjustable in four positions:
0,79 – 1,02 – 1,20 – 1,40 m.
(2,6 ft. – 3,35 ft. – 3,9 ft. – 4,6 ft.)

1. To change the axle width on the rear set of wheels, place the outriggers in standard position-**green** for axle width: 0,79 – 1,02 – 1,20 m. (2,6 ft. – 3,35 ft. – 3,9 ft. – 4,6 ft.) Place outrigger 2+3 in **Yellow** position for axle width 1,40 m. (See section 5.2)
2. Lift all three wheels off the ground by the outriggers (See section 5.2)
3. Remove locking pin (A) for rear axles.
4. Adjust the axle width to the needed by pushing/pulling the handle (B) at the guide for axle width.
5. Lock axle position with locking pin (A).

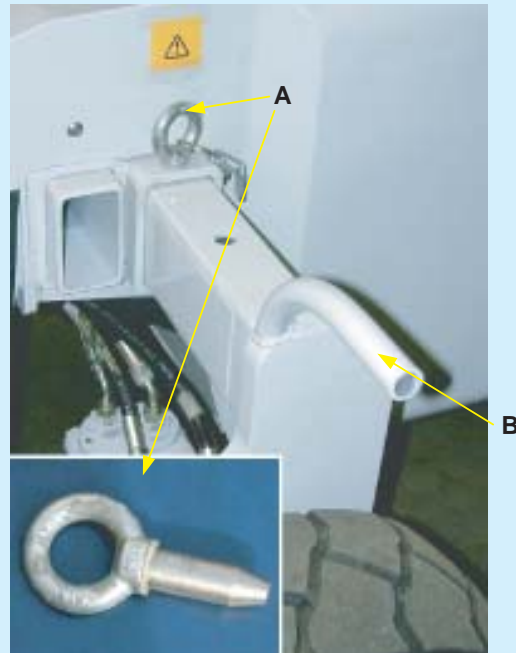

Locking for axle width.

Rear wheel – Axle width

Always use the maximum possible axle width that space allows.

WARNING

When the rear axles are not locked with the locking pin, the rear axle can fall out and the platform may tip over, causing serious injury or death.

Wheel models above 32 meter

The axle width of the rear set of wheels is adjustable in two positions:

1. completely out
2. completely in (narrow/stowed)
 1. Lift all wheels off the ground by the outriggers (See section 5.2)
 2. Turn the switch for the electrical emergency pump on.
 3. Move the handle until both axles are completely out or completely in.

**WARNING**

Do not attempt to drive the lift if the axles are not completely out or completely in. The platform may tip over, causing serious injury or death.

WARNING

When driving the platform with the axles in the stowed position, keep the platform on hard, flat ground and in low speed. If the platform is driven on a slope it can tip over and cause injury or death.

IMPORTANT



Use the widest axle width possible at all times.

5.2 Setting up the outriggers

General

Before using the chassis functions (Driving and outrigger functions):

Retract the telescopes completely.
Fold in the link arm
Main boom in centre (The green information signal (E) at the control panels lights up).
Main boom down.

1. Make sure that the battery main switch is in position "ON". The battery main switch (Suppl. C, Pic. I) is located at the side of the platform next to the switch for the emergency pump. Always remember to keep the platform connected to mains if possible.
2. When using the functions according to the chassis (Driving and outriggers) the platform gives an acoustic pulsing signal.
3. To set up the outriggers from Chassis control panel (suppl. A) turn the key switch (#u) to position  for Chassis Control.
4. To set up the outriggers from Basket control panel (Suppl. B) turn the key switch (#u) to position  for Basket Control.
5. When the key switch at the Chassis control panel (suppl. A) is in position Chassis control or Basket Control. The red light on all 4 outriggers and the red "stability" indicator light, on the platform control panels, at the chassis and in the basket, must be on when the platform is in stowed position or if the outriggers are without load.
Make sure always to check the red "Stability" indicator lights while the platform is in stowed position.

WARNING

Do not attempt to use the platform if the **red** lights on the outriggers or the “STABILITY” indicator lights are not **ON** when the outriggers are in stowed position or the outriggers are without a load.

If the **red** “STABILITY” indicator lights are out when the outriggers are lifted from the ground the safety system has a malfunction.

Failure in the safety system can cause injury or death.

Call an authorised service centre immediately.

6. Mount the outrigger plates at the outriggers: Turn the outriggers away from the platform by lifting the locking bolts and turn the outrigger away.



Fig. 9 Locking bolt

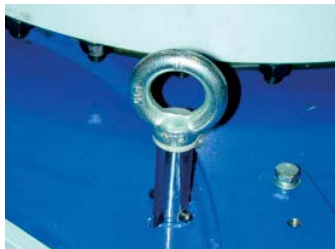

Fig. 10 Locking bolt lifted



Fig. 11 Locking bolt

7. Dismount the locking pin from the axle and remove the axle.

Mount the foot plates at the outriggers and secure it with the axle and locking pin



Fig. 12 Outrigger turned away from the platform



Fig. 13 Locking pin

Fig. 14 Foot plate mounted and secured



Fig. 15 Axle and foot plate

WARNING

Outrigger plates must always be mounted at the outrigger and secured before attempting to lift the platform off the ground.

8. When the four outrigger plates are secured the outriggers must be placed and secured/locked with the locking bolt.

WARNING

Setting up the platform on soft ground can make the platform unstable and cause serious injury or death.

Only set up the platform on hard flat ground.

Load applied to the ground is given in the technical data.

Setting up the outriggers – General

9. Each outrigger can be placed in three different positions. The outreach of the platform depends of the load in the basket and the

positions of the outriggers.
(See outreach diagram)

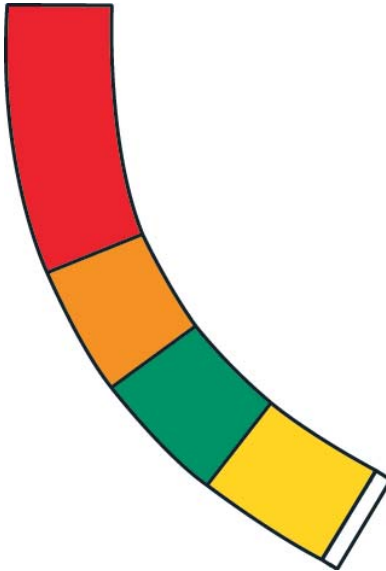

Fig. 16 Outrigger positions



Fig. 17 Outrigger in standard position.



Fig. 18 Locking bolt

Fig. 16:
Transportation position **Red**. Only for transportation to achieve the min. width 1,2 m. (Stowed position).
Position – **Orange** (30° to chassis).
Position – **Green** (45° to chassis) Standard.
Position – **Yellow** (60° to chassis).

Fig. 17:
Outrigger base an chassis frame.

Fig. 18:

Locking bolt. Locking bolt must always be in position before attempting to set up the platform on outriggers.

8. Place the outriggers in the best possible horizontal position. If possible use the standard position – **Green** (45° to the chassis) and always lock with the locking bolt to the chassis frame.

The outriggers must as a minimum be in position – **Orange** before the outriggers are lowered, otherwise the outriggers will collide with the chassis.

When the four outriggers has been placed and secured/locked to the chassis frame the outriggers can be lowered by the outrigger control handles placed underneath the Chassis control panel (suppl. A) or by the Basket control panel (Suppl. B) (Option).

CAUTION

When lowering the outriggers make sure that there is no interference with the pumps and diesel engine. Do not lower the outriggers when they are locked in the stowed position. This is not a working position and can cause interference with chassis resulting in structural damage.

WARNING

**When lowering the outriggers, do not lift the platform more than 0,6 m. from the ground.
The platform does not stop automatically. Failing to do so can cause injury or death.**

WARNING

**If the outrigger base of the outrigger is not locked to the chassis frame the outriggers can turn, resulting in instability which can cause injury or death.
Locking bolt for securing the outrigger base to the chassis frame must always be in position before attempting to lift the platform off the ground.**

5.2.01 Setting up the outriggers from Chassis control panel (suppl. A)

Overview operations locations

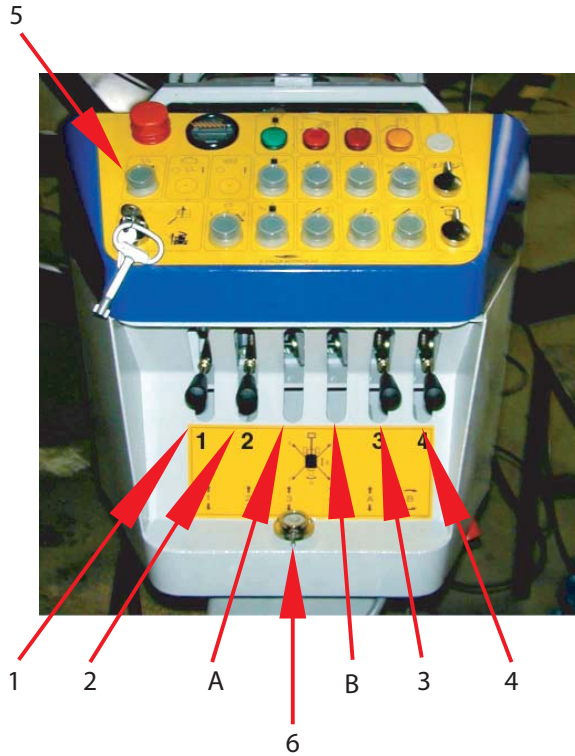

Fig 19a Outrigger control handles at crawler models

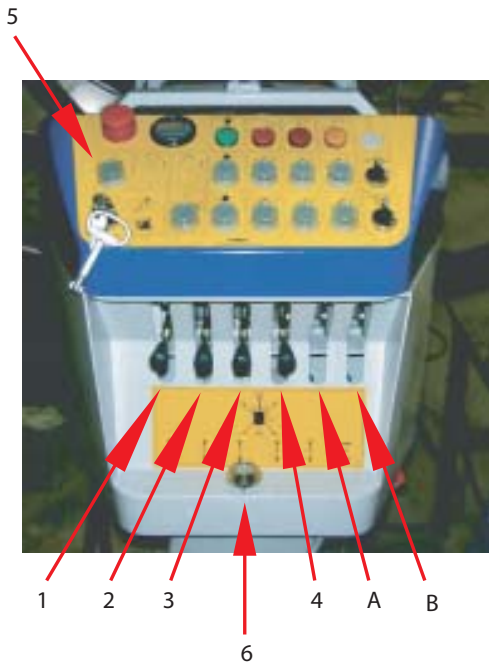

Fig 19b Outrigger control handles at wheel models

Description:

- 1 Outrigger control-handle for outrigger 1 up/down
- 2 Outrigger control-handle for outrigger 2 up/down
- 3 Outrigger control-handle for outrigger 3 up/down
- 4 Outrigger control-handle for outrigger 4 up/down
- 5 Push button for START PUMP
- 6 Spirit level

On crawler models:

(Fig 19a)

A. Turns the tracks to the right - forward or backward.
(Handle not mounted, only for emergency)

B. Turns the tracks to the left - forward or backward.
(Handle not mounted, only for emergency)

B. Turns the tracks to the left - forward or backward.
(Handle not mounted, only for emergency)

On wheel models:

(Fig 19b)

A. Driving the platform forward/backward
(Handle not mounted, only for emergency)

B. Valve for turning the front wheel clockwise/counter-clockwise
(Handle not mounted, only for emergency)

Setting up the outriggers from the chassis

To set up the outriggers do as followed:

1. Place the outriggers in the chosen position.
2. Turn the key switch at Control panel-Chassis

to position chassis. 

3. Push the button **START PUMP** (#h) at the Chassis control panel (suppl. A).

4. Bring the outriggers to the ground by the control handles.

It is recommended to bring all 4 outriggers in contact with the ground one by one.

5. Lower the outriggers two at the time (1 and 4 together - 2 and 3 together) by the outrigger control handles to give an equal pressure on each outrigger.

6. The platform shall be lifted from the ground until all tracks/wheels no longer have contact with the ground.

When the outriggers are pressed to the ground the **red** stability indicator lights, at the outriggers shall turn off.

7. When setting up the outriggers, the platform must be on hard flat ground. Make sure the platform is in horizontal level by checking the spirit level located at the chassis frame.



Fig. 20 Spirit level

WARNING

When positioning the outriggers on the ground it is important to ensure that all limbs are kept clear of the outriggers, outrigger plates and any other moving parts.

Failing to do so can cause injury or death.

WARNING

Setting up the platform out of horizontal level to the ground can give instability and cause injury or death.

The platform must be set up with chassis in horizontal level.

The outreach of the platform depends on how the outriggers are placed. Wider outrigger span and lower basket load means longer outreach.

In order to achieve the maximum working height the platform must be raised 0,6 m./2ft off the ground measured from the ground to underneath the wheels.
(see outreach diagram)

Pay attention to the free rotation of the turret!

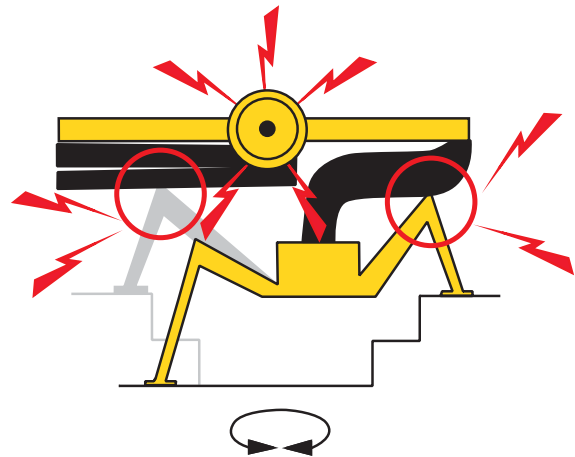

5.2.02 Setting up the outriggers from the Basket control panel (Suppl. B) (Option)

To set up the outriggers from the Basket control panel (Suppl. B) do as follows:

1. Place the outriggers in the chosen position.
2. Turn the key switch at Control panel-Chassis to position Basket. 
3. Enter the basket.
4. Turn the selector switch (#x) at the Basket control panel (Suppl. B) to position chassis marked with a B

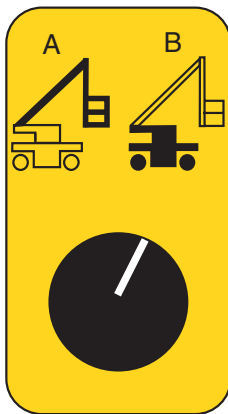

Fig. 21 Turnable switch

5. Use the left joystick to control the outriggers according to the left label on Basket control panel (Suppl. B) marked with a B.
6. Bring the outriggers to the ground by the left joystick and press left side of the selector switch marked with one dot •.
7. Lower the outriggers two at a time (1 & 4 together and 2 & 3 together) by the Left joystick to give an equal pressure on each outrigger.
8. The platform shall be lifted from the ground until all tracks or wheels no longer have contact with the ground.
When the outriggers are pressed to the ground the red stability indicator lights at the outriggers shall turn off.
9. When setting up the outriggers the platform must be on hard flat ground. Make sure the platform is in horizontal level by checking the spirit level located at the link arm system.

WARNING

When positioning the outriggers on the ground it is important to ensure that hands, feet etc. are kept clear of the outriggers, outrigger plates and any other moving parts.
Failing to do so can cause injury or death.

WARNING

Setting up the platform out of horizontal level to the ground can give instability and cause injury or death.
The platform must be set up with chassis in a horizontal level.

WARNING

Do not attempt to use the platform if the red indicator lights at the outriggers are not ON when the outriggers are in stowed position or the outriggers are without a load.
If the red “STABILITY” indicator lights are out when the outriggers are lifted from the ground, the safety system has a malfunction.
Failure in the safety system can cause injury or death.
Call an authorised service centre immediately.

The outreach of the platform depends on how the outriggers are placed. Wider outrigger span and lower basket load means longer outreach.

In order to achieve the maximum working height the platform must be raised 0,6m/2ft. off the ground, measured from the ground to underneath the wheels.
(see outreach diagram).

5.2.03 Setting up outriggers automatically (Option)

As option the outriggers can be set up automatically in horizontal level and the pressure in the hydraulic system equalised by a push button at the Chassis control panel (suppl. A, #v) or by a push button at the Basket control panel (Suppl. B, #v)

It is recommended only to use automatic set up for the outriggers at horizontal surfaces and with the outriggers in standard position (45° to chassis – Green).

1. Bring the outriggers in position, and lock them with the locking bolt.
(According to the procedure in section 5.2)
2. Push the button (#v) continuously and the outriggers will be set up.
3. The platform is in horizontally level and the pressure in the hydraulic system of the outriggers is equalized when the green Information signal (C) starts flashing, and the operator can now release the button (#v).
4. If the platform needs to be lifted higher from the ground repeat procedure 2 and 3.

To lift the outriggers from the ground use the control handles for the outriggers (Chassis control panel or the joystick (Control panel – Basket).

WARNING

Do not attempt to use the platform if the red indicator lights at the outriggers are not ON, when the outriggers are in stowed position or the outriggers are without a load.

If the red “STABILITY” indicator lights are out when the outriggers are lifted from the ground, the safety system has a malfunction.

Failure in the safety system can cause injury or death.

Call an authorised service centre immediately.

5.2.04 Stowing the outriggers

The outriggers can be stowed in the following order:

1. Retract the telescopes
2. Fold in the link arm system
(The jib and basket jib)
3. Main boom in centre
4. Move the main boom down
5. Leave the basket
6. Dismount the basket, if needed
7. Lift the outriggers from the ground two by two (1 & 4 together - 2 & 3 together) by the outrigger handles
8. Remove the outrigger plates if needed.
9. Bring the outriggers in stowed position and lock them with the locking bolts

In order to achieve the minimum height, width and length according to the technical data, the basket and the outrigger plates must be dismantled and the outriggers placed in stowed position (Red).

WARNING

Do not set up the platform, when the outriggers are in Red position (Suppl. C, Pic II) (Stowed position).

This is ONLY transport position.

Failing to do so can be a cause for injury or death.

5.3 Before using the platform

5.3.01 Mounting the basket

1. Mount the basket at the two brackets (A) at the console for the Basket Control Panel.
2. Secure the basket with the two locking pins (B)
3. Safety belt can be mounted at the two fixing-points (C)

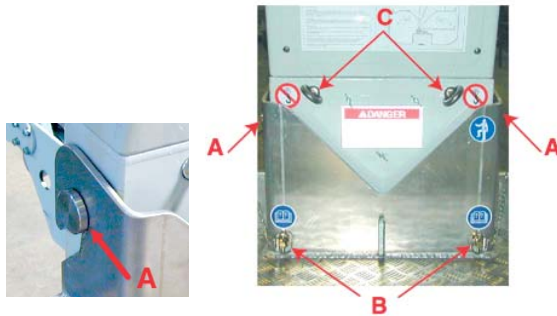

Fig. 22 Mounting the basket

WARNING

When mounting the basket make sure that the basket is locked properly. A basket not locked properly can fall off and cause injury or death.

WARNING

When the platform is used for welding work the platform has to be unplugged and the outriggers have to be placed on rubber mats.

5.3.02 Power supply

If mains are not available it is possible to work without being connected to the mains outlet. To avoid discharging the batteries the battery charger shall, if possible, always be plugged in.

Optional:

- 24V DC motor and diesel engine.
- Diesel engine (option on wheel models)
- AC motor (option).

5.3.03 Diesel engine (Optional for wheel models)

The platform, if equipped with a diesel engine, it can be started and stopped from the turnable switch on the Chassis control panel (suppl. A, #i) or at the Basket control panel (Suppl. B, #i)

The turnable switch (#i) have 3 positions

O = Diesel engine stopped

☆ = Ignition for diesel engine

I = Diesel engine starter/preheater

The turnable switch comes on red when the diesel engine is started. If the red light flashes in the turnable switch the fuel level is low. Refill fuel as soon as possible.

By turning the switch (#i) to I, hold it till it starts (app. 30 seconds). The engine is preheating before it starts.

By turning the switch (#i) to ignition and not starting the engine, it will after app. 10 sec. automatically cut of. After this it is necessary to turn the switch (#i) back to position O and then to position I.

REMARK: The turnable switch (#i) activates only the functions by change.

As an example:

If the diesel engine is operated from the Chassis control panel (suppl. A) turn the key switch (#u) to position Chassis and turn the switch (#i) to position I. When the diesel motor starts let go of the switch (#i), and the switch returns automatically to position

The switch (#i) at the Basket control panel (Suppl. B) will still be in position O . The red light in the switch will come on to indicate that the motor is running. To turn off the engine from the Basket control panel (Suppl. B) turn the key switch (#u) to position



Turn the switch (#i) to position ☆ and then to position O and the motor will stop/turn off.



Diesel engine (Lombardini)

The information lights for the diesel engine are placed at the end of the platform



Fig. 23



1. Air filter. The light comes on when the filter is blocked



2. 12V/24V generator. The light comes on when there is no charging to the 12V/24V generator



3. Oil pressure. The light comes on when oil pressure of the diesel motor is too low



4. Water temperature. The light comes on at high temperature

When the diesel engine is running it will charge at the batteries of the platform.

When the diesel engine is running all functions of platform will be power supplied from the diesel engine.

Other pumps will not be started

Service- and maintenance of the diesel engine is according to the Operators instructions for the Lombardini diesel engine.

Generator (Honda)

If a generator (available as option) is mounted, it is operated from the control panel located at the generator.

When using the generator, place the plug (see picture below) in one of the AC receptacles, and the generator supplies the battery charger, and the mains outlet in the basket.



Plug

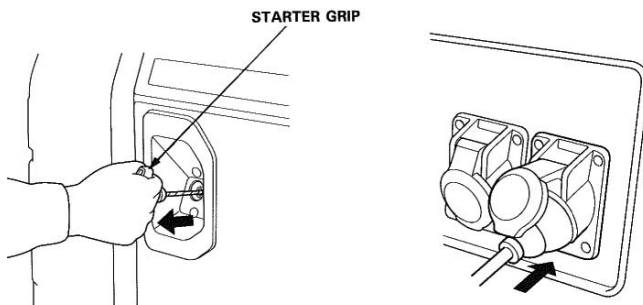
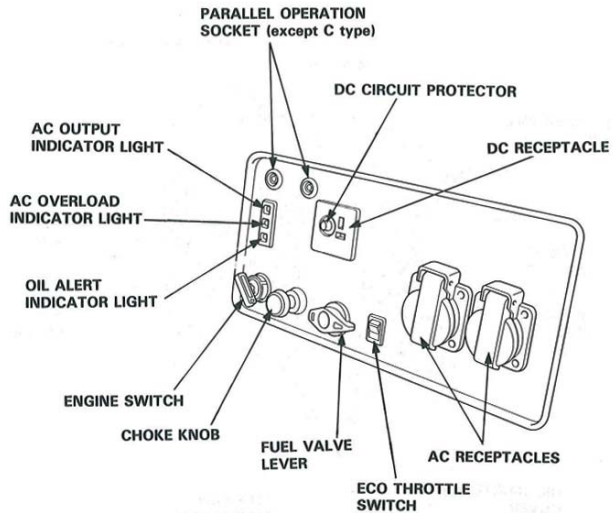

1. Turn the fuel valve lever to ON position.
2. Pull the choke knob out to closed position.
NOTE: Do not use the choke when the engine is warm or the air temperature is high.
3. Push the Eco throttle switch to position OFF.
4. Turn the engine switch to ON the position. Turn the engine switch shortly to starting position.
5. If there is no battery capacity or at models with manual starter:
Pull the starter grip lightly until resistance is felt, then pull the starter grip briskly.
6. Push the choke knob to the open position as the engine warms up.
7. Push the Eco throttle switch to position ECO.
Please follow the instructions in the HONDA Owner's MANUAL.

5.4 Operating the platform

Personnel who needs to gain access i.e. for maintenance and cleaning operations can use the platform.

The platform is not insulated for working with or near high voltage installations and the platform may not be used for any other purpose than to give access for personnel. The platform may not be used as a crane and large objects may not be placed in the basket or at the boom i.e. large label or windows.

Contact between platform or basket and fixed objects i.e. buildings shall be avoided.

WARNING

The basket is not insulated for work with or near high voltage installation.

Work in assured clear distance from electrical power lines.

Failing to do so can result in electrocution causing injury or death.

WARNING

Do not attempt to climb outside the basket when it is lifted from the ground.

Always make sure you use a safety belt as required by your employer or the appropriate fall protection.

Falling from the platform can cause injury or death.

WARNING

Do not attempt to climb on top of the basket or to use a ladder or likewise from the basket.

WARNING

Overloading the platform can cause serious injury or death.

Do not overload the basket, or attempt to use the basket or the platform as a crane.

WARNING

Before entering the basket it must be controlled that the basket is properly locked to the basket suspension. Do not attempt to use the platform without the use of a safety belt. The safety belt must be properly locked in the fixing point. Incorrect operating of procedures can cause injury or death.

1. Read the complete manual and the safety instructions, and make sure to perform the daily inspection checks before attempting to use the platform.

2. Set up the platform as according to section 5.2.

3. Make sure that the battery main switch (Suppl. C, Pic. I) is in position "ON". The battery main switch is located at the right side of the platform next to the switch for the emergency pump.

4. The platform can be operated from Basket control panel (Suppl. B) or from the Chassis control panel (suppl. A) in the front end of the platform.

To operate the platform from the basket, turn the key switch (#u) located on the Chassis control panel (suppl. A) to position. 

5. To operate the platform from the ground, turn the key switch (#u) located on the Chassis control panel (suppl. A) to  position.

6. Enter the basket (max. 200 kg.)

NOTICE

When operating the platform from the basket – All movements are proportional
When operating the platform from the chassis the movements have predefined speed by push buttons.

7. With the platform in stowed position use the following unpacking procedure according to the label at the Link-arm system to prevent damage to the platform:

- Raise the main boom.
 - Extend the telescopes, until there is enough space to fold out the Link-arm system.
- Before activating the Link-arm system and/or the Jib, the Telescopes shall be extended until there is space between the Link-arm system and the covers.
- Fold out the Link-arm system.

WARNING

Always pay attention to the position of the outriggers, turret and Link-arm system while slewing.

There can be danger of collision between outrigger(s) and Link-arm system and/or between the turret and outrigger(s). Failing to do so can cause structural damage to the platform.

WARNING

When folding out the Link-arm system, make sure there is no collision between the Link-arm system and the cover(s). Raise the main boom and extend telescopes before folding out the Link-arm system.

Failing to do so can cause structural damage to the platform.

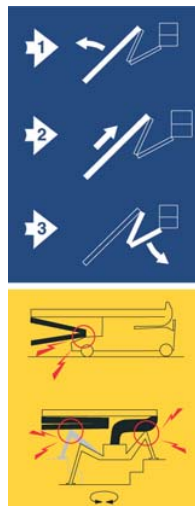

Fig. 24 Label for the unpacking procedure located at the Link-arm system and turret.

5.4.01 Basket control panel
Description

By operating the platform from the Basket control panel (Suppl. B), the operator must choose between using the platform functions or the chassis functions.

The selection is done by a turnable selector switch (#x) which is located on the Basket control panel (Suppl. B).

The platform function is marked with an A
 The chassis function is marked with a B

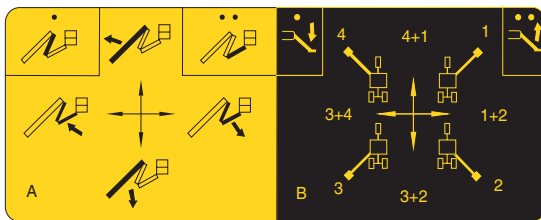

Fig. 25 Left side

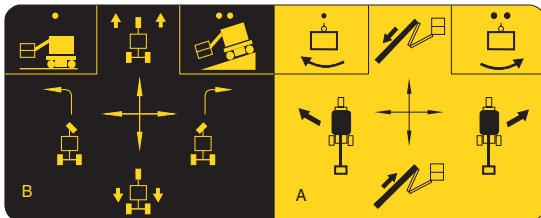

Fig. 26 Right side

Selecting the platform functions A-activates only the functions in the left side of the label and in the right side of the label marked with an A, and both with yellow background.

Selecting the chassis functions B-activates only the functions in the right side of the label and in the left side of the label marked with a B and both with black background.

Two joysticks control the functions.

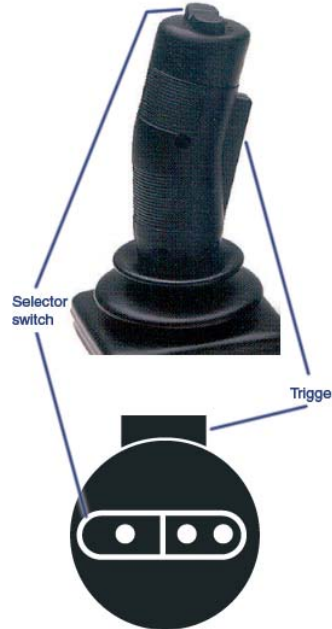

Fig. 27 Joystick

The functions at the label **left side** are controlled by joystick at the left side (joystick 1 Suppl. B) and the functions at the labels right side are controlled by joystick at the right side (joystick 2 Suppl. B).

The joysticks are two-hand controlled, by a trigger. When using the joystick press the trigger continuously.

The joysticks 1 and 2 are equipped with a selector switch.

The selector switch can be pressed in 2 positions.

To the right, marked with 2 dots: ••
 To the left, marked with 1 dot: •

The dots refer to the dots at the label. By pressing the selector switch to the left or right, the function of the joystick refers to the pictogram in the same box as the chosen dot(s).

In the pictogram the colour filled part is the active part.

Joystick 1 (Left)

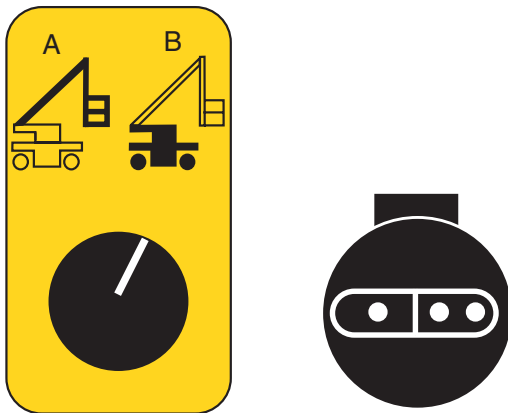

Fig. 28 Turnable Selector switch (#x)

Joystick 1

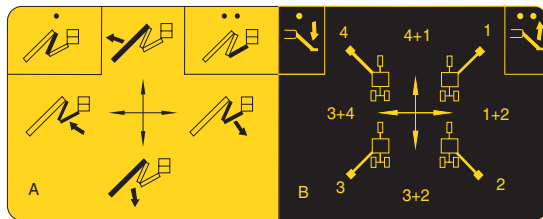

Fig. 29 Left label

The selection is done by a turnable selector switch (#x) which is located on the Basket control panel (Suppl. B)

Platform functions activated (Yellow)

1. Press the joystick selector switch to • and hold it: activates only the JIB.
2. Press the joystick selector switch to •• and hold it: activates only the Basket JIB.

Chassis functions activated (Black)

3. Press the joystick selector switch to • and hold it: activates Outriggers DOWN.
4. Press the joystick selector switch to •• and hold it: activates Outriggers UP.

PLATFORM functions (Yellow) LEFT joystick 1

1. Movement of the **MAIN BOOM UP**
By pushing joystick 1 upwards, the main boom will move up (#q).
2. Moving the **MAIN BOOM DOWN**.
By pulling joystick 1 downwards, the main boom will move down (#r).

3. Moving of JIB and Basket JIB.
By moving joystick 1 to the left, the jib and the basket jib are folding in (#p).

(The jib and the basket jib are not moving 100% simultaneously, therefore it can be necessary to adjust the **JIB** and **Basket JIB** one by one.)

By pressing the 2 dots •• only the **Basket JIB** will fold in, when moving joystick 1 to the left.
By pressing the 1 dot • only the JIB will fold in, when moving joystick 1 to the left.

4. Movements of JIB and Basket JIB.

By moving joystick 1 to the right, the jib and the basket jib are folding out (#o).

(The jib and the basket jib are not moving 100% simultaneously therefore it can be necessary to adjust the **JIB** and **Basket JIB** one by one.)

By pressing the 2 dots •• and hold it and move the joystick to the right only the **Basket JIB** will fold out.

By pressing the 1 dot • and hold it and move the joystick to the right only the **JIB** will fold out.

Chassis functions (Black) LEFT joystick 1

1. Moving **Outrigger 1**.

By moving the joystick diagonal up to the right and pressing the 1 dot • **Outrigger 1** moves down.

By moving the joystick diagonal up to the right and pressing the 2 dots •• **Outrigger 1** moves up.

2. Moving **Outrigger 1&2**.

By moving the joystick to the right and pressing the 1 dot • **Outrigger 1&2** moves down.

By moving the joystick to the right and pressing the 2 dots •• **Outrigger 1&2** moves up.

3. Moving **Outrigger 2**.

By moving the joystick diagonal down to the right and pressing the 1 dot • **Outrigger 2** moves down.

By moving the joystick diagonal down to the

right and pressing the 2 dots •• **Outrigger 2** moves up.

4. Moving **Outrigger 3&2**.

By moving the joystick down and pressing the 1 dot • **Outrigger 3&2** moves down.

By moving the joystick down and pressing the 2 dots •• **Outrigger 3&2** moves up.

5. Moving **Outrigger 3**.

By moving the joystick diagonal down to the left and pressing the 1 dot • **Outrigger 3** moves down.

By moving the joystick diagonal down to the left and pressing the 2 dots •• **Outrigger 3** moves up.

6. Moving **Outrigger 3&4**.

By moving the joystick to the left and pressing the 1 dot • **Outrigger 3&4** moves down.

By moving the joystick to the left and pressing the 2 dots •• **Outrigger 3&4** moves up.

7. Moving **Outrigger 4**.

By moving the joystick diagonal up to the left and pressing the 1 dot • **Outrigger 4** moves down.

By moving the joystick diagonal up to the left and pressing the 2 dots •• **Outrigger 4** moves up.

8. Moving **Outrigger 4&1**.

By moving the joystick up and pressing the 1 dot • **Outrigger 4&1** moves down.

By moving the joystick up and pressing the 2 dots •• **Outrigger 4&1** moves up.

Joystick 2 (Right)

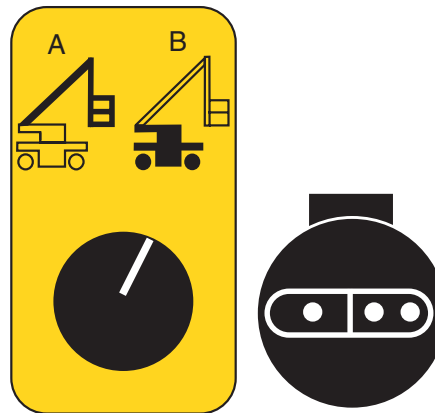

Fig. 30 Selector switch (#x)

Joystick 2

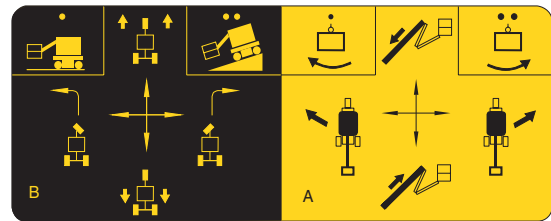

Fig. 31 Right label

The selection is done by a turnable selector switch (#x) which is located on the Basket control panel (Suppl. B).

Chassis functions activated (Black).

1. Press the joysticks • : activates low traction (Fast speed)
2. Press the joysticks •• : activates high traction (Low speed)

Platform functions activated (Yellow)

Chassis functions (Black) Joystick 2 (RIGHT)

Rotation

For platforms with wheels or platforms with tracks taller than 32m/105ft, the front wheels or tracks turns. At smaller track models the entire platform turns.

1. Turn/rotate right

By moving joystick 2 to the right, the front belt will turn/rotate CW.

(When the front tracks/wheels is turned, and the operator lets go of the joystick, the front track/wheel will not automatically go back to middle position. The front track/wheel will stay in the turned position until it is turned in the opposite direction.)

By moving the joystick diagonal up to the right, the platform turns CW and drives forward.

By moving the joystick diagonal down to the right, the platform will turn CCW and drive backward.

4. Turn/rotate left

By moving joystick 2 to the left, the front track/wheel will turn/rotate CCW.

(When the front track/wheel is turned, and the operator lets go of the joystick, the front track/wheel will not automatically go back to middle position. The front track/wheel will stay in the turned position until it is turned in the opposite direction.)

By moving the joystick up to the left, the platform turns CCW and drive forward.

By moving the joystick diagonal down to the left, the platform will turn CW and drive backward.

5. Driving backwards

By pulling down joystick 2 the platform will drive backward.

6. Forward driving

By pushing joystick 2 up the platform will drive forward.

Platform functions (Yellow) Joystick 2 (RIGHT)

1. RETRACT Telescopes

By pushing the joystick 2 up (#n) the telescopes will retract.

2. EXTEND Telescopes

By pulling joystick 2 down (#m) the telescopes will extend.

3. Slewing COUNTER CLOCKWISE

By moving joystick 2 to the right (#k) the turret of platform will slew counter-clockwise.

Raise the main boom until it is in horizontal level before slewing is possible.

4. Slewing CLOCKWISE

By moving joystick 2 to the left (#l) the turret of the platform will slew clockwise.

Raise the main boom until it is in horizontal level before slewing is possible.

5. Basket ROTATION (#y)

Pictogram for the push button at the top of joystick 2.

When using the platform functions choose between basket rotation clockwise or counter-clockwise.

By pressing the left push button marked with 1 dot • the basket rotation will be clockwise.

By pressing the left push button marked with 2 dots •• the basket rotation will be counter clockwise.

To stop the basket rotation release the joystick selector switch.

5.4.02 Basket control panel

Description of the functions (Suppl. B)

Chassis functions and PLATFORM functions

1. Caution signal – **LOW BATTERY CAPACITY**

When the **red** light (#w) comes on the capacity at the battery is below than 50%.

If it flashes it means that the charger is not connected or it indicates a fault. Please check the charger.

If the charger is connected and the **red** light still shines leave the platform momentarily and let it charge the batteries.

If the SPIDER is equipped with a diesel engine, it can be started.

2. Warning signal – **STABILITY.**

If the **red** stability light (#d) on the basket control panel comes on and the platform functions stops the main reason is that the limit for sufficient stability is reached. (This is normally caused by maximum outreach with the given basket load compared to the span of the outriggers)

As long as the **red** lights are shining only the functions that increase stability can be used:

RETRACT Telescopes #s
MAIN BOOM UP #n

3. Warning signal - **Basket LOCKED**

If the basket tilts more than 10° it will automatically secure its position and the **red** light (#e) comes on. If possible move the main boom or the Link arm system in the opposite direction, until the basket is back at horizontal level and the **red** light turns off. (section 6.1.01)

4. Caution signal – **MOVEMENTS BLOCKED**

If the light comes on (#f) the basket jib is out of it's allowed working area (vertical) either upwards or downwards. Only functions bringing it back to allowed working area can be used now.

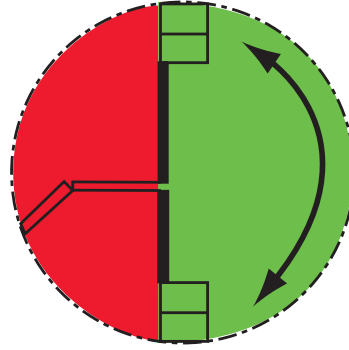

Fig. 32 Movements blocked
Green area is allowed working area.

5. Warning signal – **Basket OVERLOAD**

If there is an overload of the rated basket load the light (#g) will flash.

6. Diesel Engine

By turning the switch (#i) to I, hold it till it starts (app. 30 seconds). The engine is preheating before it starts.

By turning the switch (#i) to ignition and not starting the engine, it will after app. 10 sec. automatically cut of. After this it is necessary to turn the switch (#i) back to position O and then to position I.

7. EMERGENCY STOP BUTTON.

To release the Emergency stop button (#a) pull it.

8. MAIN BOOM in Centre

Information signal (#c). When the main boom is in centre, the **green** light will come on. Every time the main boom passes the centre the **green** light will come on for a few seconds. (Option)

This light is also used for auto set up. See point 9.

9. AUTO SET UP Outriggers (Option)

Push button (#v) automatically sets up the outriggers at horizontal level and equalises the pressure in the hydraulic system of the outriggers.

It is recommended, only to use automatic set up for the outriggers at horizontal surfaces and with the outriggers in standard position. (45° to chassis – **green** position at the label)

1. Bring the outriggers in position, and lock them with the locking bolt.
(According to the procedure in section 5.2)
2. Push the button (**#v**) continuously and the outriggers will be set up.
3. The platform is at horizontal level and the pressure in the hydraulic system of the outriggers is equalised, when the **green** information signal (**#c**) starts flashing. The operator can now release the button (**#v**).
4. Does the platform need to be lifted further from the ground, repeat the procedure 2 + 3.

5.4.03 Chassis control panel Description (suppl. A)

1. Turnable key switch (#u) with 3 positions:

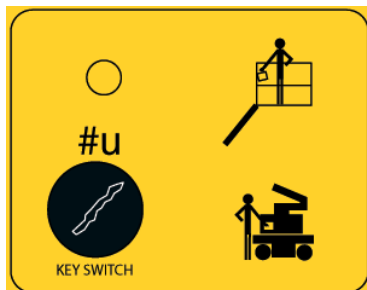

Fig. 33

O = Off

 = Operate the platform from the control panel in the basket.

 = Operate the platform from the control panel at the Chassis.

When operating the platform from the basket, it is recommended to remove the key to prevent unauthorised use of the platform.

2. Push button.
(#h) Start the pump for the outriggers.
3. Emergency stop button.
To release the Emergency stop button, (#a) pull it.
4. Turnable switch (3 positions)
ON/OFF for the diesel engine (#i)

For turning the diesel engine on, turn the switch to position I.

(By turning the switch to I, hold it till it starts (app. 30 seconds). The engine is preheating before it starts.

By turning the switch to ignition and not starting the engine, it will after app. 10 sec. automatically cut of.

After this it is necessary to turn the switch back to position O and then to position I.)

When the engine is running release the switch and it'll turn back to the middle position and the **white** light in the switch shines. If the **white** light is flashing, the fuel level is low.

To stop the diesel engine, turn the switch to position O

5. BATTERY INDICATOR.

(#b)
See 3.1.07

6. 220V pump. (Option)
(#j)

7. Information signal – **MAIN BOOM IN CENTRE**

Information signal (#c). When the main boom is at centre, the **green** light will shine. Every time the main boom passes the centre the **green** light will shine for a few seconds.

This light is also indicating when the outriggers are at horizontal level. (Option)

When setting up the outriggers automatically, the information signal (**green** light) will flash when the outriggers are in horizontal level and the pressure in the hydraulic system is equalised.

8. Warning signal – **STABILITY.**

If the **red** stability light (#d) on the basket control panel and one or more on the outriggers come on and the platform functions stops the main reason is that the limit for sufficient stability is reached. (This is normally caused by maximum outreach with the given basket load compared to the span of the outriggers)

As long as the **red** lights come on only the functions that increase stability can be used:

RETRACT Telescopes #s
MAIN BOOM UP #n

9. Warning signal - **BASKET LOCKED.**

If the basket tilts more than 10° it will automatically secure its position and the **red** light (#e) come on. If possible move the main boom or the Link arm system in the opposite direction, until the baskets back at horizontal level and the **red** light turns off.

(section 6.1.01)

10. Caution signal – **MOVEMENTS BLOCKED.**

If the light shines (#f) the link arm has reached it's maximum working area (vertical) either upwards or downwards. Only functions increasing the the security can now be used.

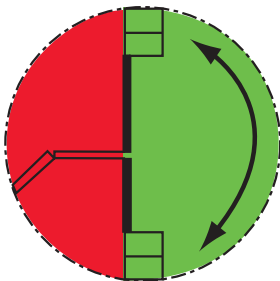

Fig. 34 Movements blocked

11. Turnable switch

(#s) Spring loaded to centre, for movement of only the **JIB** or the **Basket JIB**

If it is needed to move **only the Basket JIB**, turn the switch to the right and hold it and at the same time push one of the buttons (#p) folding in or (#o) out and the **Basket JIB** will move. To stop the movement, release the buttons.

12. Push button - **MAIN BOOM UP**

(#q) By pushing the button the main boom moves up. Release the button to stop the movement.

13. Push button - **MAIN BOOM DOWN.**

(#r) By pushing the button the main boom moves down. Release the button to stop the movement.

14. Turnable spring loaded switch for **BASKET ROTATION.**

(#t) When turning the switch, the basket will rotate depending of which side the switch is turned to. Release the switch to stop the basket rotation.

15. Push button - Movement of **LINK ARM SYSTEM.**

(#p) By pushing the button the jib and the basket jib are folding in. Release the button to stop the movement.

The jib and the basket jib are not moving 100% simultaneously, therefore it can be necessary to adjust the **JIB** and **Basket JIB** one by one.

16. Push button – **RETRACT TELESCOPES.**

(#n) By pushing the button the telescopes retract. Release the button to stop the movement.

17. Push button – **EXTEND TELESCOPES.**

(#m) By pushing the button the telescopes extends, release the button to stop the movement.

18. Push button – **SLEWING CLOCKWISE.**

(#l) By pushing the button the turret will slew clockwise, release the button to stop the movement.

Raise the main boom until it is in horizontal level and extend the telescopes app. 150 mm. before slewing is possible.

19. Push button – **slewing COUNTER-CLOCKWISE.**

(#k) By pushing the button the turret will slew counter-clockwise. Release the button to stop the movement.

Raise the main boom until it is in horizontal level and extend the telescopes app. 150 mm. before slewing is possible.

20. Push button - OUTRIGGER SET UP

(#v) Automatically sets up the outriggers in horizontal level and equalises the pressure in the hydraulic system of the outriggers. (Option)

It is recommended only to use automatic set up for the outriggers, at horizontal surfaces and with the outriggers in standard position (45° to chassis – **Green**).

- Bring the outriggers in position and lock them with the locking bolt
(According to the procedure in section 5.2)
- Pressing the button continuously the outriggers will be set up.
- The outriggers are in horizontal level and the pressure in the hydraulic system of the outriggers is equalised, when the **green** information signal starts flashing, and the operator can release the button.
- If the platform needs to be lifted further from the ground, repeat the procedure.



6.0 Emergency lowering General

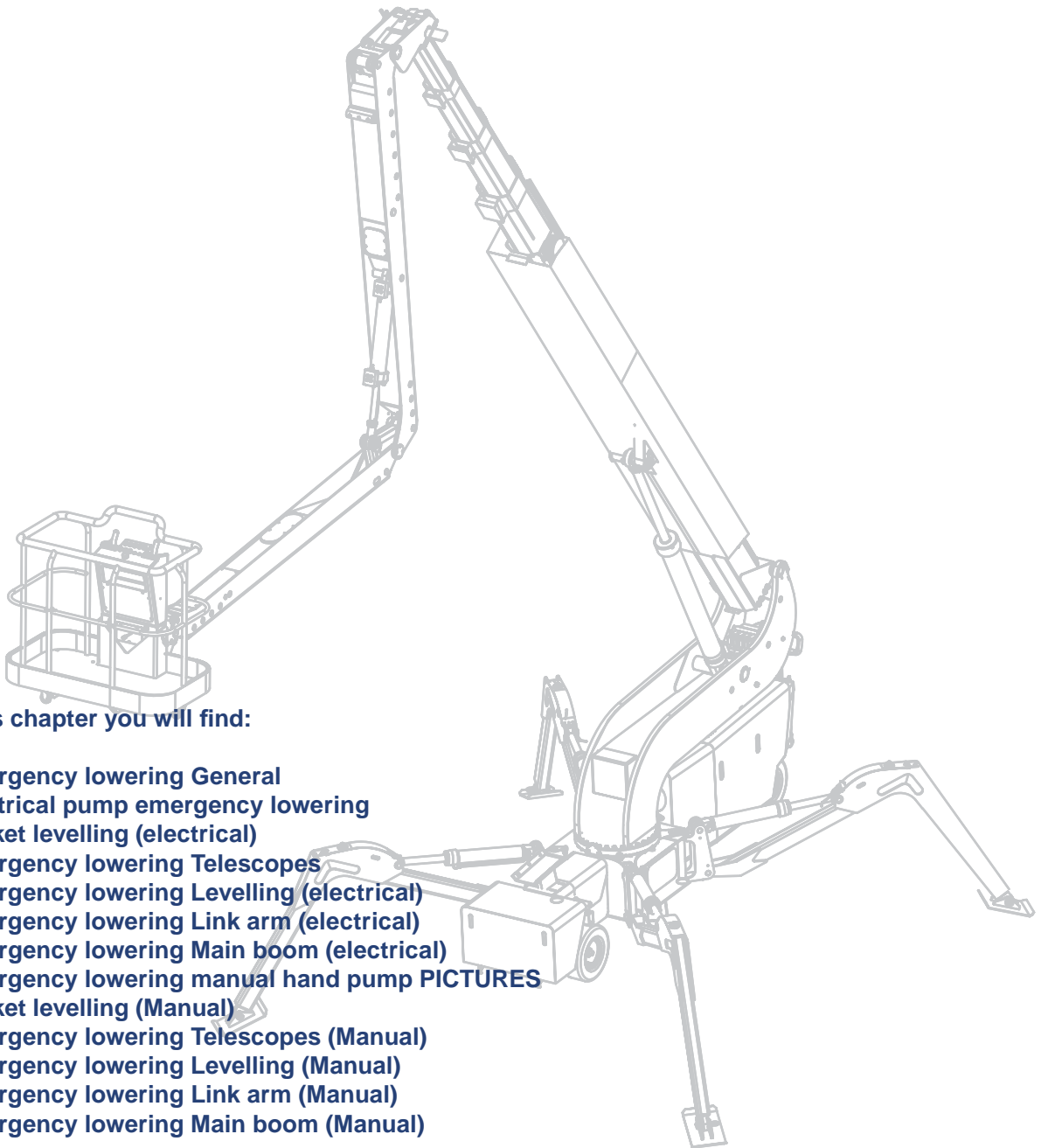

In this chapter you will find:

- Emergency lowering General
- Electrical pump emergency lowering
- Basket levelling (electrical)
- Emergency lowering Telescopes
- Emergency lowering Levelling (electrical)
- Emergency lowering Link arm (electrical)
- Emergency lowering Main boom (electrical)
- Emergency lowering manual hand pump PICTURES
- Basket levelling (Manual)
- Emergency lowering Telescopes (Manual)
- Emergency lowering Levelling (Manual)
- Emergency lowering Link arm (Manual)
- Emergency lowering Main boom (Manual)

6.0 Emergency lowering General

In emergency situations or in case the electrical controls are malfunctioning, it is needed to use the emergency pump or manual hand pump. The platform function emergency valves are placed at the turret.

IT IS RECOMMENDED, IF POSSIBLE, TO RETRACT THE TELESCOPES FIRST.

When activating the emergency valves, the stability system is not working. See WARNING below.

WARNING

When operating the platform from the ground, by engaging the emergency valves directly, the safety system of the platform is out of function. When operating the platform directly from the emergency valves “Telescope in” is the only function to be used until the telescope is fully retracted.

Failing to do so, can cause personnel injury or death.

Call authorised maintenance immediately.

It is recommended to make every move very slow to prevent damage to buildings, windows etc.

The emergency valves are controlled by the emergency lowering kit, placed in a bag, at the chassis.

The emergency lowering kit consists of four parts:

1. One Emergency handle marked **Red** to operate the basket levelling valve.
2. One Emergency handle marked **Blue** to operate the LS-valve.
3. One Emergency handle without any mark, for the movements of the platform according to the label (Suppl. D)
4. A handle for the manual hand pump/crawler hand pump.

By emergency lowering, the operator must mount one or more of the handles at the turret. The **blue** handle goes to the emergency valve marked with a **blue** dot and so on. See photo.

If there is still power at the batteries (The electrical emergency pump starts when it is activated) follow the emergency procedure (electrical) at section 6.1

If the electrical emergency pump does not start, follow the emergency procedure (Manual) at section 6.2

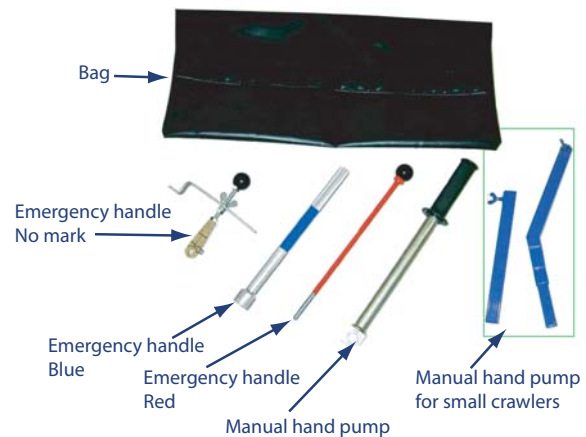

Fig. 35 Emergency lowering Kit and bag



Fig. 36 Label placed at turret, please see Suppl. D



You will find the emergency lowering kit near this sign.

Emergency lowering – General

By emergency lowering with the electrical emergency pump is it not necessary to dismount the cover at the platform.

To use the manual hand pump dismount the cover at the platform.

Left side

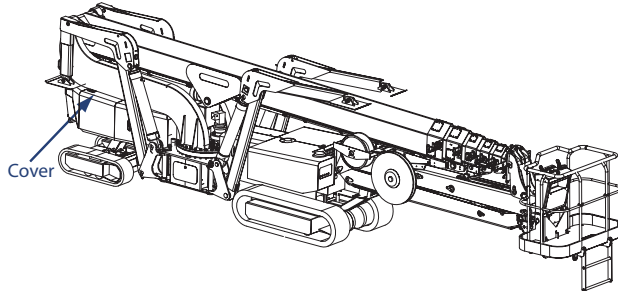

Fig. 37

Right Side

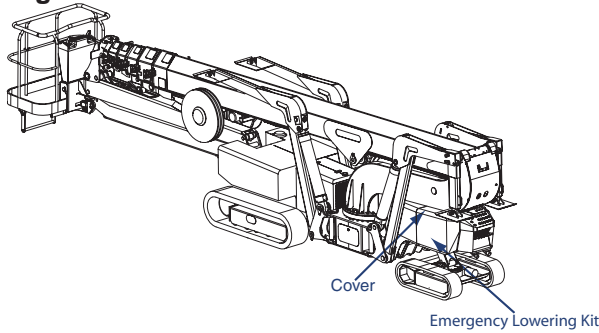

Fig. 38

**6.1 Electrical pump
Emergency lowering**

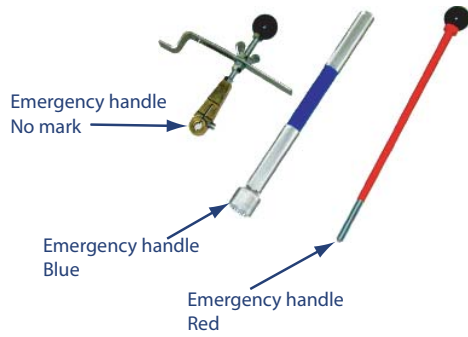

Fig. 39 Emergency tools

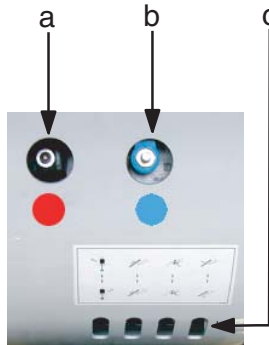

Fig. 40 Basket levelling valves

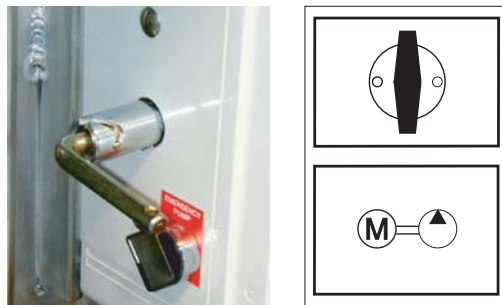

Fig. 41 Handle for electrical emergency pump and main switch

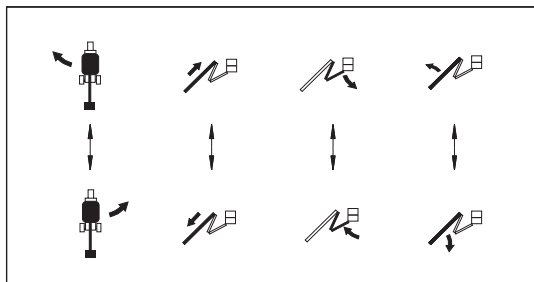

Fig. 42 Label for emergency lowering



Fig. 43 Cover in the basket



Fig. 44 Basket levelling valve

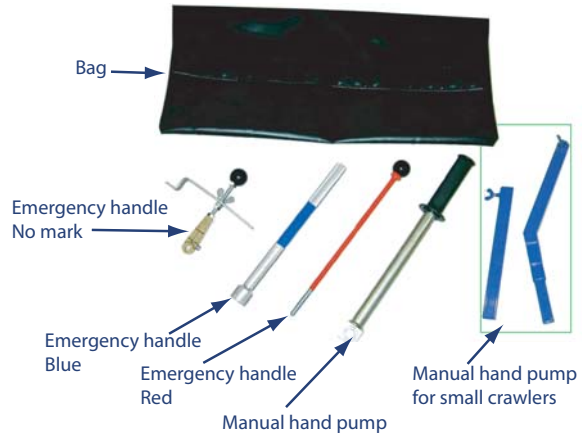

Fig. 45 Emergency kit with bag



Fig 45a Green ball plug valve for emergency lowering



6.1.01 Basket levelling (electrical)

See pictures in the beginning of this chapter 6.1

In emergency lowering situations, the basket levelling has to be done manually.

It is needed to have two persons to adjust the basket.

Person 1 at the ground and Person 2 in the basket.

To level the basket, do as followed:

- Person 1 mounts the emergency handle-Red at the basket levelling valve-Red (40a).
- Person 1 turns ON the switch for the electrical emergency pump, located next to the main switch.
- Person 2 dismounts the cover in the basket.
- Pull or push the handle for basket levelling to adjust the basket **DOWN** or **UP**.
- When basket leveling has completed, dismount the emergency handle-Red and place it under the cover at the chassis of the platform. Mount the cover.

WARNING

When activating the Emergency valves at the turret, the safety system of the platform is out of function. It is necessary to operate the platform very carefully and pay highly attention to every move. Failing to do so can cause injury or death.

6.1.02 Emergency lowering Telescopes (electrical)

See pictures in the beginning of this chapter 6.1 and below.



46a

IT IS RECOMMENDED, IF POSSIBLE, TO RETRACT THE TELESCOPES FIRST.

Extend Telescopes

1. Turn the switch for the electrical emergency pump.
2. Mount the blue emergency handle at the blue emergency valve (40b).
3. Mount the emergency handle without marking at the emergency valve for telescopes (40c), according do the label (42).
4. Move the emergency handle up slowly and the Telescopes will extend
5. When emergency lowering is completed, dismount the emergency lowering kit and turn off the emergency pump.

Retract Telescopes

1. Turn the switch for the electrical emergency pump.
2. Mount the emergency handle without marking at the emergency valve for telescopes (40c), according do the label (42).
3. Move the emergency handle down slowly and the Telescopes will retract.
4. When emergency lowering is completed, dismount the emergency lowering kit and turn off the emergency pump.

WARNING

When activating the Emergency valves at the turret, the safety system of the platform is out of function. It is necessary to operate the platform very carefully and pay highly attention to every move. Failing to do so can cause injury or death.

6.1.03 Emergency lowering Levelling (electrical)

See pictures in the beginning of this chapter 6.1 and below.

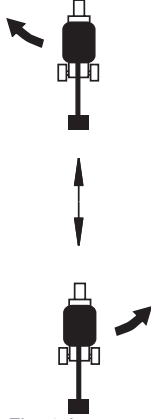

Fig. 46b

WARNING

When activating the Emergency valves at the turret, the safety system of the platform is out of function. It is necessary to operate the platform very carefully and pay highly attention to every move. Failing to do so can cause injury or death.

IT IS RECOMMENDED, IF POSSIBLE, TO RETRACT THE TELESCOPES FIRST.

Levelling clockwise

1. Turn the switch for the electrical emergency pump.
2. Mount the **blue** emergency handle at the **blue** emergency valve.
3. Mount the emergency handle without marking at the emergency valve for levelling, according to the label.
4. Move the emergency controller up slowly and the turret will slew clockwise
5. When emergency lowering is completed, dismount the emergency lowering kit and turn off the emergency pump.

Levelling counter-clockwise

1. Turn the switch for the electrical emergency pump.
2. Mount the **blue** emergency handle at the **blue** emergency valve.
3. Mount the emergency handle without marking at the emergency valve for levelling, according to the label.
4. Move the emergency controller down slowly and the turret will slew counter-clockwise.
5. When emergency lowering is completed, dismount the emergency lowering kit and turn off the emergency pump.

6.1.04 Emergency lowering Link arm (electrical)

See pictures in the beginning of this chapter 6.1 and below



Fig. 47 It is recommended, if possible, to retract the telescopes first.

It is not possible to move the jib and basket jib one by one at emergency lowering.

Fold out the Link-arm system.

1. Turn the switch for the electrical emergency pump.
2. Mount the **blue** emergency handle at the **blue** emergency valve (40b).
3. Mount the emergency handle without marking at the emergency valve for the Link arm system, according to the label (47).
4. Move the emergency handle up slowly and the Link arm system will fold out
5. When emergency lowering are completed, dismantle the emergency lowering kit and turn off the emergency pump.
6. The operator in the basket must re-level the basket

Fold in the Link arm system

1. Turn the switch for the electrical emergency pump.
2. Mount the **red** emergency handle at the **red** emergency valve (40a).
3. Mount the **blue** emergency handle at the **blue** emergency valve (40b).
4. Mount the emergency handle without marking at the emergency valve for the Link arm system, according to the label.
5. Move the emergency handle down slowly and the Link arm system will fold in.
6. When emergency lowering are completed, dismantle the emergency lowering kit and turn off the emergency pump.
7. The operator in the basket must re-level the basket

WARNING

When activating the Emergency valves at the turret, the safety system of the platform is out of function.

It is necessary to operate the platform very carefully and pay highly attention to every move.

Failing to do so can cause injury or death.

6.1.05 Emergency lowering Main boom (electrical)

See pictures in the beginning of this chapter 6.1 and below.



Fig. 48 It is recommended, if possible, to retract the telescopes first.

Main boom up.

1. Turn the switch for the electrical emergency pump.
2. Mount the **red** emergency handle at the **red** emergency valve.
3. Mount the emergency handle without marking at the emergency valve for the Main boom according to the label (48).
4. Move the emergency handle up slowly and the Main boom will move up.
5. When emergency lowering is completed, dismount the emergency lowering kit and turn off the emergency pump.
6. The operator in the basket must re-level the basket.

Main boom down

1. Mount the **blue** emergency handle at the **blue** emergency valve.
2. Mount the **red** emergency handle at the **red** emergency valve.
3. Turn the switch for the electrical emergency pump.
4. Mount the emergency handle without marking at the emergency valve for the Main boom, according to the label.
5. Move the emergency handle down slowly and the Main boom will move down.
6. When emergency lowering is completed, dismount the emergency lowering kit and turn off the emergency pump.
6. The operator in the basket must re-level the basket

WARNING

When activating the Emergency valves at the turret, the safety system of the platform is out of function.

It is necessary to operate the platform very carefully and pay highly attention to every move.

Failing to do so can cause injury or death.

6.2 Emergency lowering Manual hand pump

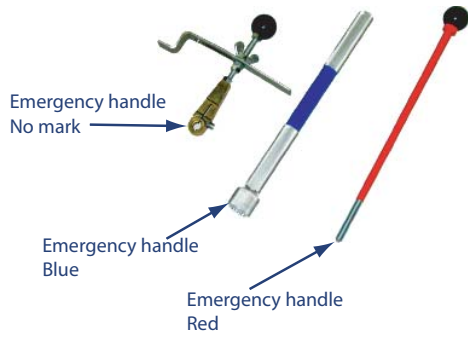

Fig. 49 Emergency tools

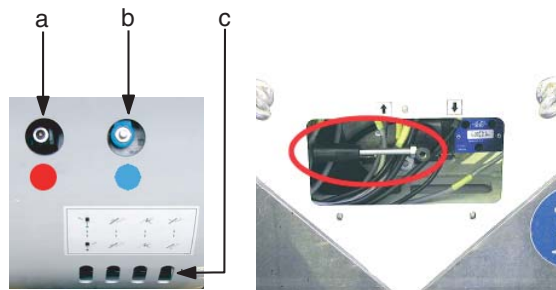

Fig. 50 Emergency controls

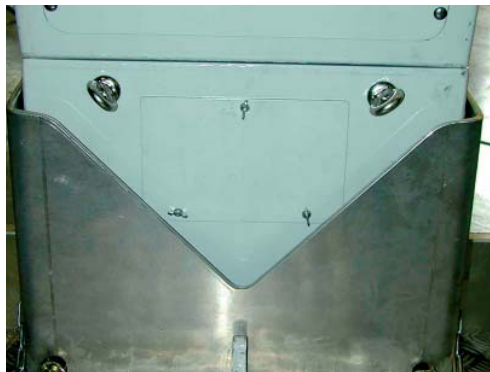

Fig. 51 Cover in the basket

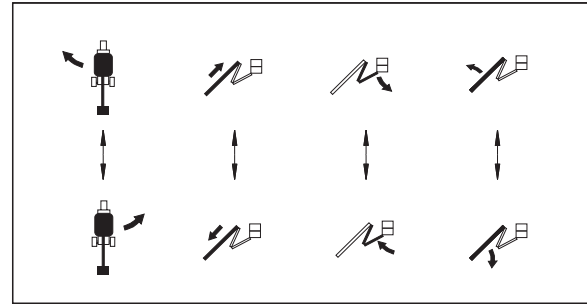

Fig. 52 Emergency label

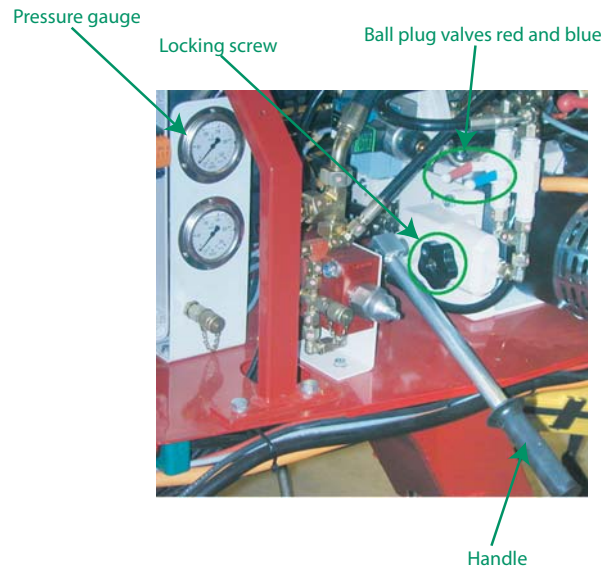

Fig. 53

6.2.01 Basket levelling (Manual)

See pictures in the beginning of this chapter 6.2

In emergency lowering situations, the basket levelling has to be done manually.

Person 1 at the ground and Person 2 in the basket.

To level the basket, do as follows:

1. Person 1 mounts the emergency handle-Red at the basket levelling valve-Red (40a).
2. Person 1 shall use the manual emergency pump.

Person 1 mounts the handle, at the manual hand pump. Open the ball plug valve-Red, close the ball plug valve-Blue and pump with the handle to give oil pressure for the basket levelling function until the red pressure gauge shows app. 160 bar. Then person 1 closes the ball plug valve-Red and opens the ball plug valve-Blue.

When the pressure gauge shows 100-160 bar, and the ball plug valve-Red is closed and the ball plug valve-Blue is open. Person 1 can use the emergency lowering according to the platform functions, while Person 2 levels the basket

3. Person 2 dismounts the cover in the basket.
4. Person 2 activates the handle at the basket-levelling valve.

- Pull the handle for basket levelling to adjust the basket the **DOWN**.
- Pushing the handle (**I**) for basket levelling to adjust the basket the **UP**.

5. If the basket stops levelling and still needs adjustment, repeat the procedure from 2 to 4

6. Person 1 must pump with the handle for the manual hand pump, simultaneously with Person 2 to pushes the handle for basket levelling.

WARNING

When activating the Emergency valves at the turret, the safety system of the platform is out of function. It is necessary to operate the platform very carefully and pay highly attention to every move. Failing to do so can cause injury or death.

7. When basket levelling has completed, mount the cover.

8. Dismount the handle for the manual hand pump and place it under the cover at the chassis.

9. Dismount the emergency controller and place it under the cover at the chassis.



6.2.02 Emergency lowering Telescopes (Manual)

It is needed to have two persons to adjust the basket.

The **green** ball plug valve is only available at platforms taller than 32 m/105 ft.

Before starting the manually emergency lowering, close the **green** ball plug valve in the turret. The **green** ball plug valve is normally open (parallel to the pipes).

The valve must be opened again after end of procedure.



Green ball plug valve

3. Push the emergency handle up for extension, down for retraction and lock it with the thumb screw.

4. Mount the handle located under the cover (right side) on the manual hand pump at the left side of the platform.

5. To give oil pressure for the platform movements, check the ball plug valves, located under the cover at the right side of platform.

The plug valve-**Red** shall be closed.

The plug valve-**Blue** shall be open.

6. Turn the locking screw if mounted, clockwise to close.

7. While pumping the handle the Telescopes extends or retracts.

8. When emergency lowering is completed, dismantle the emergency handles and the handle for the emergency pump.

IT IS RECOMMENDED, IF POSSIBLE, TO RETRACT THE TELESCOPES FIRST.

See pictures in the beginning of this chapter 6.2 and below.



Fig. 55

Extend Telescopes

1. Mount the **blue** emergency handle at the **blue** emergency valve. (40b) Continue to pt. 2

Retract Telescopes

2. Mount the emergency handle without marking at the emergency valve for telescopes, according to the label.

6.2.03 Emergency lowering Levelling (Manual)

IT IS RECOMMENDED, IF POSSIBLE, TO RETRACT THE TELESCOPES FIRST.

Levelling clockwise or counter-clockwise

1. Mount the **blue** emergency handle (40b) at the **blue** emergency valve.
2. Mount the emergency handle without marking at the emergency valve for levelling, according to the label.
3. Push the emergency handle up for clockwise levelling, down for counter clockwise levelling, and lock it with the thumb-screw
4. Mount the handle, located under the cover (right side), at the manual hand pump, on the right side of the platform.
5. To give oil pressure for the platform movements, check the ball plug valves, located under the cover at the right side of platform.
 - The ball plug valve-**Red** shall be closed.
 - The ball plug valve-**Blue** shall be open.
6. Make sure, that the locking screw is closed clockwise.
7. While pumping the handle the turret will slew clockwise.
8. When emergency lowering is completed, dismount the emergency handles and the handle for the emergency pump.

6.2.04 Emergency lowering Link arm (Manual)

IT IS RECOMMENDED, IF POSSIBLE, TO RETRACT THE TELESCOPES FIRST.

IT IS NOT POSSIBLE TO MOVE THE JIB AND BASKET JIB ONE BY ONE AT EMERGENCY LOWERING.

Fold out or fold in the Link arm system.

1. Mount the **blue** emergency handle at the **blue** emergency valve and the **red** emergency handle at the **red** emergency valve.
2. Mount the emergency handle without marking at the emergency valve for the link arm system, according to the label.
3. Push the emergency handle up if you want to fold out the link arm and move it down if you need to fold in the link arm.
Now lock it with the thumb screw
4. Mount the handle, located under the cover (Left side), at the manual hand pump, on the left side of the platform.
5. To give oil pressure for the platform movements, check the ball plug valves, located under the cover at the chassis.
 - The ball plug valve-**Red** (40a) shall be closed.
 - The ball plug valve-**Blue** (40b) shall be open.
6. Make sure, that the locking screw if mounted is closed clockwise.
7. While pumping the handle the Link arm system folds out or in.
8. This brings the basket out of horizontal level, and it is needed to level the basket back to horizontal, according to the Basket levelling procedure section 6.2.01
9. If necessary repeat the procedure, and pay attention to the level of the basket.
10. When emergency lowering is completed, dismount the emergency handles and the handle for the emergency pump.

6.2.05 **Emergency lowering Main boom (Manual)**

**IT IS RECOMMENDED, IF POSSIBLE, TO
RETRACT THE Telescopes FIRST.**

Main boom up

1. Mount the emergency controller without marking at the emergency valve for the Main boom, according to the label.
Mount the **red** handle at the **red** emergency valve.

OR

Main boom down

1. Mount the **blue** emergency handle at the **blue** emergency valve and the **red** emergency handle at the **red** emergency valve.

THEN

2. Push the emergency handle up to move the main boom up push it down to move main boom down, and lock it with the thumb screw
3. Mount the handle, located under the cover at the chassis, at the manual hand pump, at the chassis.
4. To give oil pressure for the platform movements, check the ball plug valves, located under the cover at the chassis.
 - The ball plug valve-**Red** shall be closed.
 - The ball plug valve-**Blue** shall be open.
5. Make sure, that the locking screw is closed clockwise.
6. While pumping the handle the Main boom moves up or down.
7. This brings the basket out of horizontal level, and it is needed to level the basket back to horizontal, according to the basket levelling procedure section 6.2.01
8. If necessary repeat the procedure, and pay attention to the level of the basket.
9. When emergency lowering are completed, dismount the emergency handles and the handle for the emergency pump.



7.0 After end using the platform

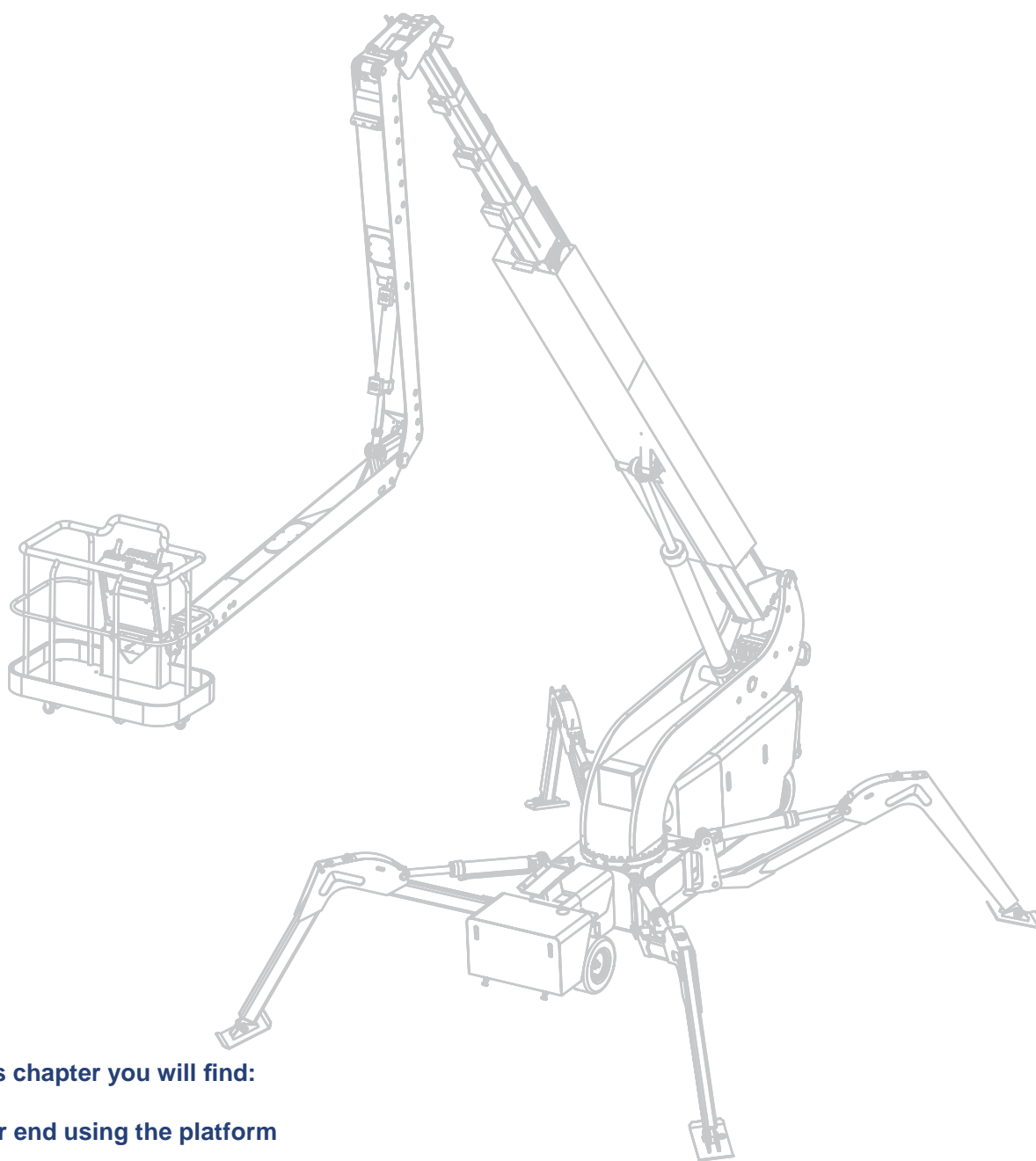

In this chapter you will find:

- **After end using the platform**

7.0 After end using the platform

Control the platform from the Chassis control panel (suppl. A).

1. Slew the turret until the **green** indicator light comes on (#c).
The main boom is now in centre.
2. Retract the telescopes to the cradle.
3. Fold in the link arm system.
4. Move the Main boom down.

CAUTION

Donot let the basket to hit the ground. This can cause structural damage to the platform.

5. Dismount the basket if necessary.
6. Raise the outriggers, and lock them in stowed **Red** position if necessary.

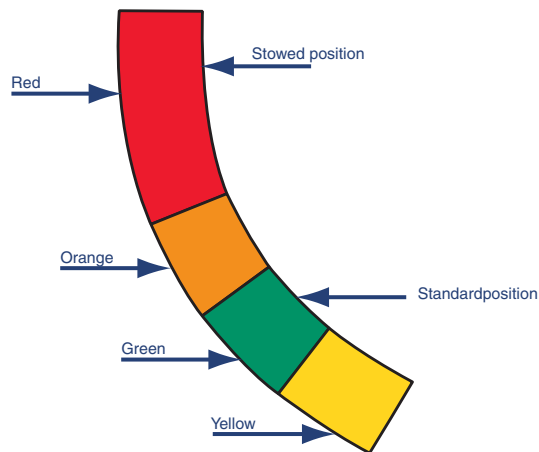

Fig. 56

CAUTION

The red stability lights at the outriggers MUST come on when the outriggers are raised from the ground. Failure in the safety system can cause injury or death. Call authorised service centre immediately.

CAUTION

When the platform is transported, the outriggers must be raised minimum 5 cm/2 inch. from the ground.

8.0 Transporting the platform

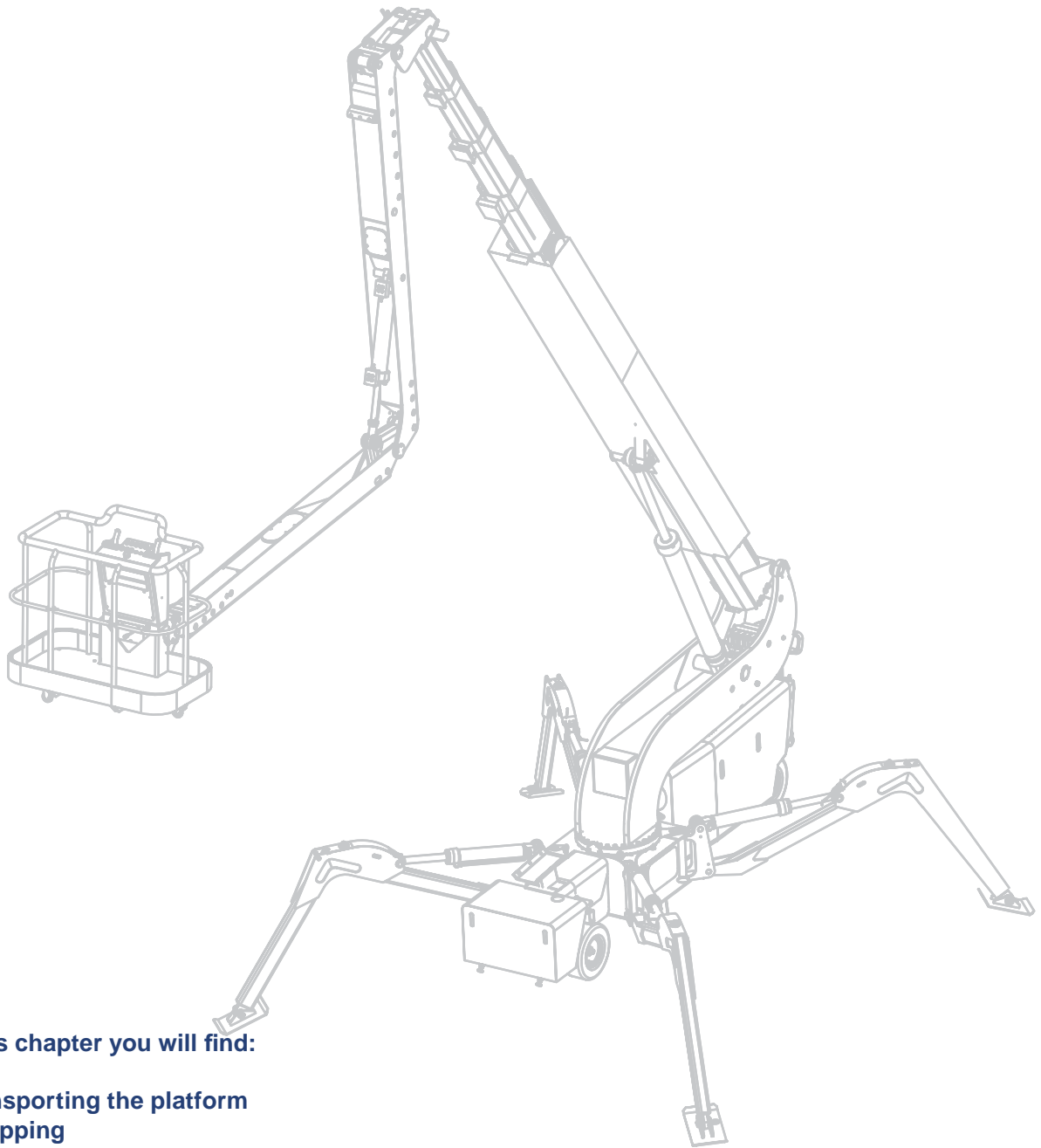

In this chapter you will find:

- **Transporting the platform**
- **Strapping**

8.0 Transporting the platform

1. Transportation over longer distances can be done by truck, trailer, etc.
2. The platform can load and off load itself by using the outriggers.
3. Lock the outriggers in standard position-**green** (45° to the chassis)

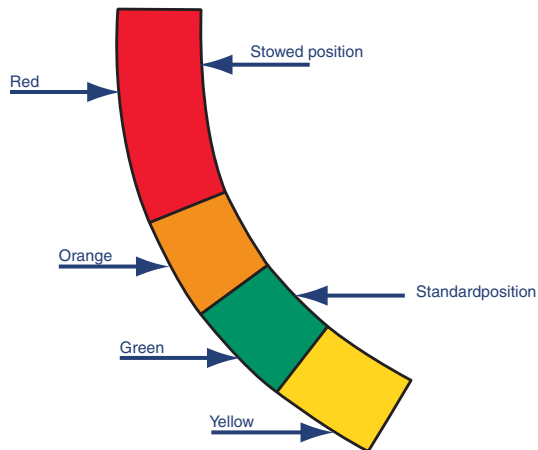

Fig. 57



Fig. 58 Platform lifted at the outriggers



Fig. 59 Truck under platform

4. Loading or unloading: Lower the outriggers to the ground, see photos until the platform is lifted enough to place a truck under it or drive away from the platform. Avoid damaging the outriggers.

5. Lift the outriggers completely from the ground and place the outriggers in **Red** position. (Stowed). In order to reach the stowed dimensions according to the General data.

CAUTION

It is important that all 4 outriggers have the same load when loading, unloading and during operation. Notice the **red** lights on the outriggers. Always keep the platform horizontal while loading and unloading.

Activate the outriggers 2 by 2, front and rear.

WARNING

Do not set up the platform when the outriggers are in **Red** position (Stowed). This is ONLY a transport position.

6. When the platform is placed on a truck, it **MUST** be securely strapped.

Please follow the procedure.

The platform must be strapped in both front and rear end and from both sides (Left and right). If possible strap the platform at the middle also.

a. Strap the platform in the rear end by the fixing points (Strap 1 - fig 60) and to a fixing points at the truck (Strap 2 - fig. 61). Remember to strap the platform in both sides.



Fig. 60 Strap 1



Fig. 61 Strap 2

b. The front end can be strapped in two different ways. From the fixing points at the turret (Strap 3 - **fig. 62**) or from the fixing points inside the turret (strap 4 - **fig. 63**) to a fixing point at the truck (strap 2 - **fig. 62**).

When using the fixing points **ALWAYS** remember to protect the turret with a piece of rubber (Strap 4 with rubber mat - **fig. 62**) or likewise.

c. From the fixing point at the front end of the belts and to a fixing point at the truck (Strap 5 - **fig. 64**).

Or from the fixing point at the rear end of the platform to a fixing point at the truck (Strap 6

- fig. 65)



Fig. 62 Strap 3



Fig. 63 Strap 4 with Rubber mat



Fig 64 Strap 5



Fig. 65 Strap 6

7. After end transportation, unload the platform using the outriggers or ramp.

9.0 Safety Instructions

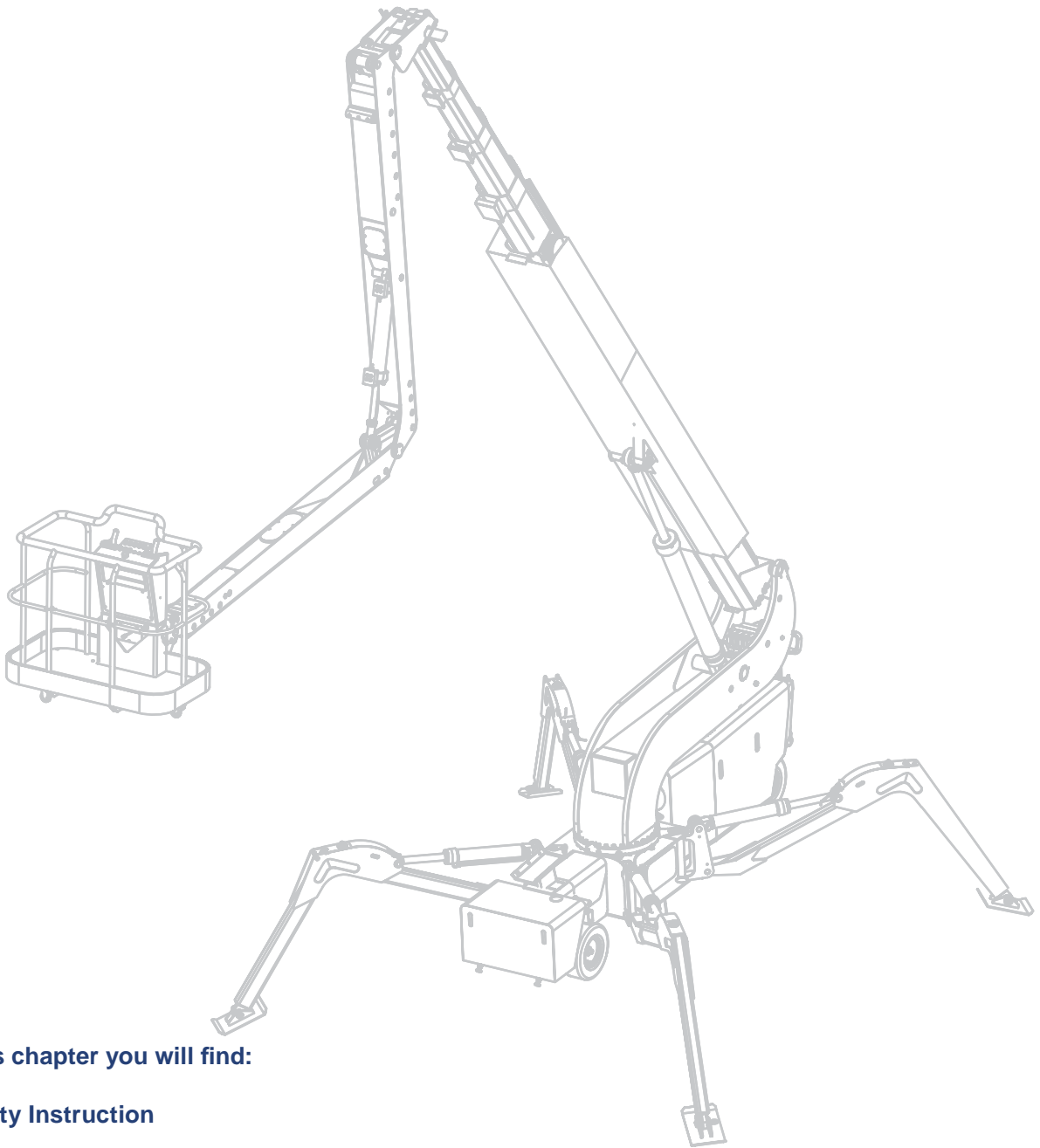

In this chapter you will find:

- **Safety Instruction**

9.0 Safety Instructions

When using the platform you must always make sure that the necessary stability is maintained. The safety system (Cut out system) secures that the maximum reachable load according to the outreach is limited, by the chosen positions of the outriggers.

When maximum capacity has been reached, a red “Stability Indicator light” comes on at the Chassis control panel (suppl. A), at the Basket control panel (Suppl. B) and on the outriggers with minimum load. This indicates that the “Cut-Out” zone has been reached.

Simultaneously, all movements that could reduce stability further are stopped. Only movements that will reduce the working radius and centre the load are permitted: **“RETRACT TELESCOPE”** and **“MAIN BOOM UP”**.

Safe work with the platform demands that the instructions for use and maintenance are followed, and that the daily inspection check is performed prior to the operation of the platform.

Check that all the labels are easily readable.

The platform must be on hard flat ground and level.

Work has to be stopped when wind exceeds 12,5 m/sec. (Wind force 6 after Beaufort).

When working on public roads or places, the working area must be corded off and surrounded by signs of flashing yellow lights according to the existing laws.

When the platform is left unattended, it must be secured against unauthorised use.

Work near high voltage installations is prohibited.
The platform is NOT insulated.

According to the CE- and national prescriptions only persons with the necessary instructions may use the platform.

When the platform is used for welding work, the platform has to be without power and the outriggers must be placed on rubber mats.

Do not use the platform without reading and following all instructions carefully.
Failure due to incorrect operating procedures and safety instructions can cause injury or death.



10.0 Inspection and maintenance

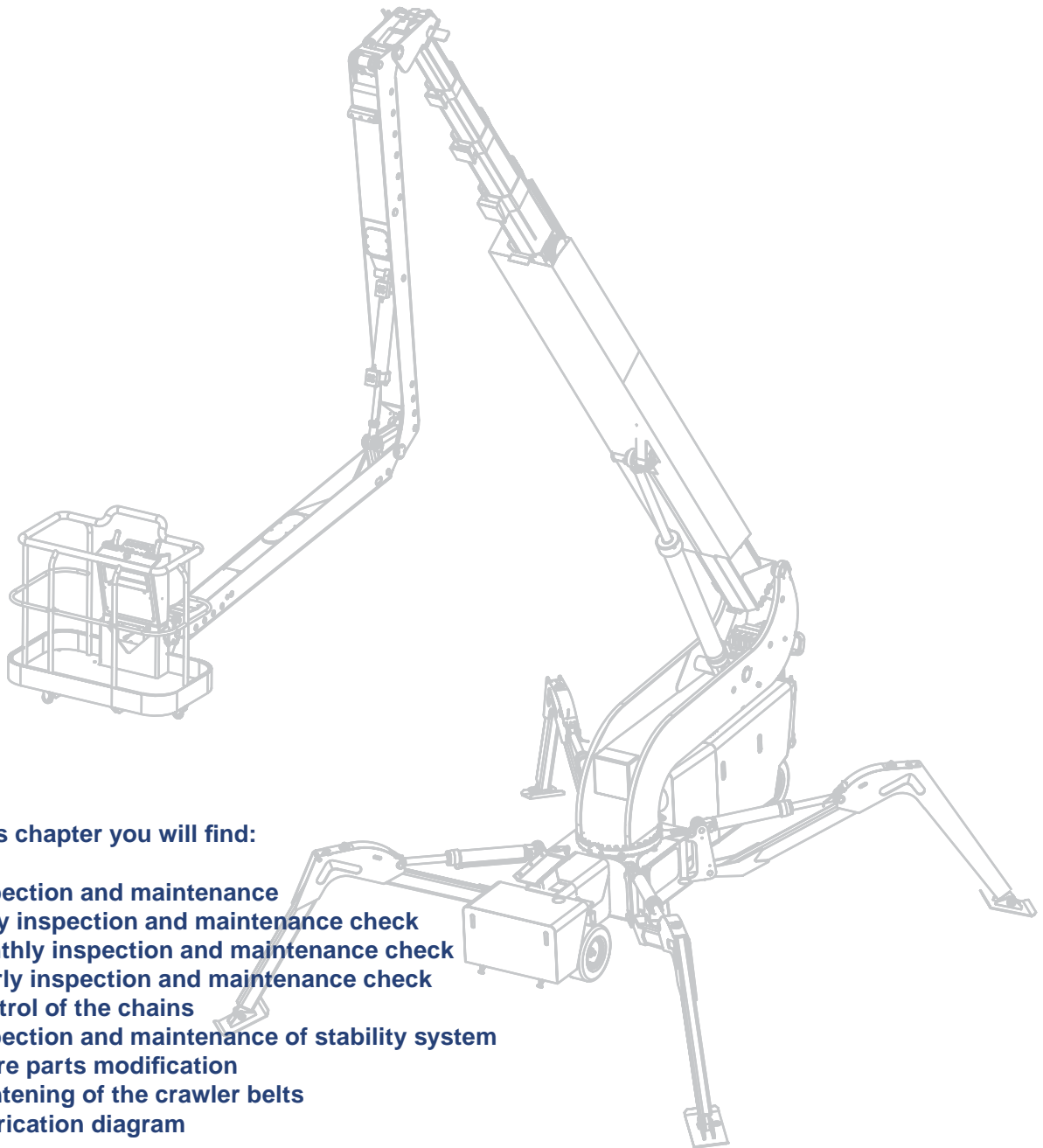

In this chapter you will find:

- **Inspection and maintenance**
- **Daily inspection and maintenance check**
- **Monthly inspection and maintenance check**
- **Yearly inspection and maintenance check**
- **Control of the chains**
- **Inspection and maintenance of stability system**
- **Spare parts modification**
- **Tightening of the crawler belts**
- **Lubrication diagram**

Inspection and maintenance

Perform inspection and maintenance for the diesel engine (Option), generator (Option) etc. according to the Operators/Maintenance manual for these parts.

10.1 Daily inspection and maintenance check

1. If the check should not be performed with the following result, the platform may not be used before all malfunctions are repaired.
2. With the outriggers lifted off the ground, check that the red „Stability Indicator lights“ is on at all outriggers and the red **“Stability Indicator light”** at the Basket control panel (Suppl. B) and at the Chassis control panel (suppl. A) are on.
3. When the platform has been set up and before operations start, please check that when maximum outreach is achieved, one or two of the red Stability Indicator light(s) on the outrigger(s) comes on together with the **“Stability Indicator light”** at the Basket controlpanel (Suppl. B) and at the Chassis control panel (suppl. A), the only functions free in this situation shall be **“RETRACT TELESCOPE”** and **“MAIN BOOM UP”** until the Stability Indicator lights are off.
4. Check the charge indicator for battery state.
5. Check that the emergency stop disables all functions of platform.
6. Check the platform for any defects such as: damaged cables or chains, hydraulic leaks, loose wiring, structural damage, damaged basket mounting brackets, tire damage, etc.

10.2 Weekly inspection and maintenance check

1. Tighten the crawler belts, according to section 10.7.

10.3 Monthly inspection and maintenance check

1. Check the oil level in the hydraulic tank, and refill as required.
2. Lubricating according to the lubrication diagram.
3. Check all cylinders for tight fit and the valves and oil pipes for leaks.
4. Tighten the wheels according to the specification Nm.



10.4 Yearly inspection and maintenance check

1. The platform must go through an annual inspection performed by a certified aerial lift company.

The annual inspection must check all lifting and supporting devices, chassis etc. for wear and tear or any defects. The platform must be checked for loose wiring and any part that need to be tightened or replaced due to normal wear and tear, damage or manufacturers defect.

All inspections and repairs must be recorded and kept in the machine file.

2. Lubrication according to the lubrication diagram.
(See section 10.8)
3. Check that turret bearing bolts has torque to specifications shown in the NM tabel.
4. Check all parts of the platform for corrosion, cracks and other damages.
5. Control of the chains:
Wear on the chains must be controlled over 10 chain links.
By controlling the length between 11 spikes.
maximum allowable wear is 2% over 10 chain links.

Platform model	Bolts in outer circle (top)	Bolts in inner circle (bottom)
FS230	M12/90 Nm.	M12/90 Nm.
FS230C	M12/90 Nm.	M12/90 Nm.
FS290	M12/90 Nm.	M12/90 Nm.
FS290C	M12/90 Nm.	M12/90 Nm.
FS290	M14/160 Nm.	M14/160 Nm.
FS290C	M14/160 Nm.	M14/160 Nm.
FS320	M14/160 Nm.	M14/160 Nm.
FS320C	M14/160 Nm.	M14/160 Nm.
FS370	M16/ 240 Nm.	M16/ 240 Nm.
FS370C	M16/ 240 Nm.	M16/ 240 Nm.
FS420	M16/ 240 Nm.	M16/ 240 Nm.
FS420C	M16/ 240 Nm.	M16/ 240 Nm.

Nm Table

Chain groups	Nom. length 1 link (mm)	Nom. length 10 Links (mm)	Nom. length with 2% wear (mm)
½" chain (12. series)	12,7	127	129,5
5/8" chain (15. series)	15,875	158,75	162
¾" chain (19. series)	19,05	190,5	194
1" chain (25. series)	25,4	254	259

10.5 Inspection and maintenance of stability system

To perform check of the stability system, a scale, with a capacity at minimum 3000 kg, is required. The minimum readout tolerance of the scale shall be no more than 5 kg.

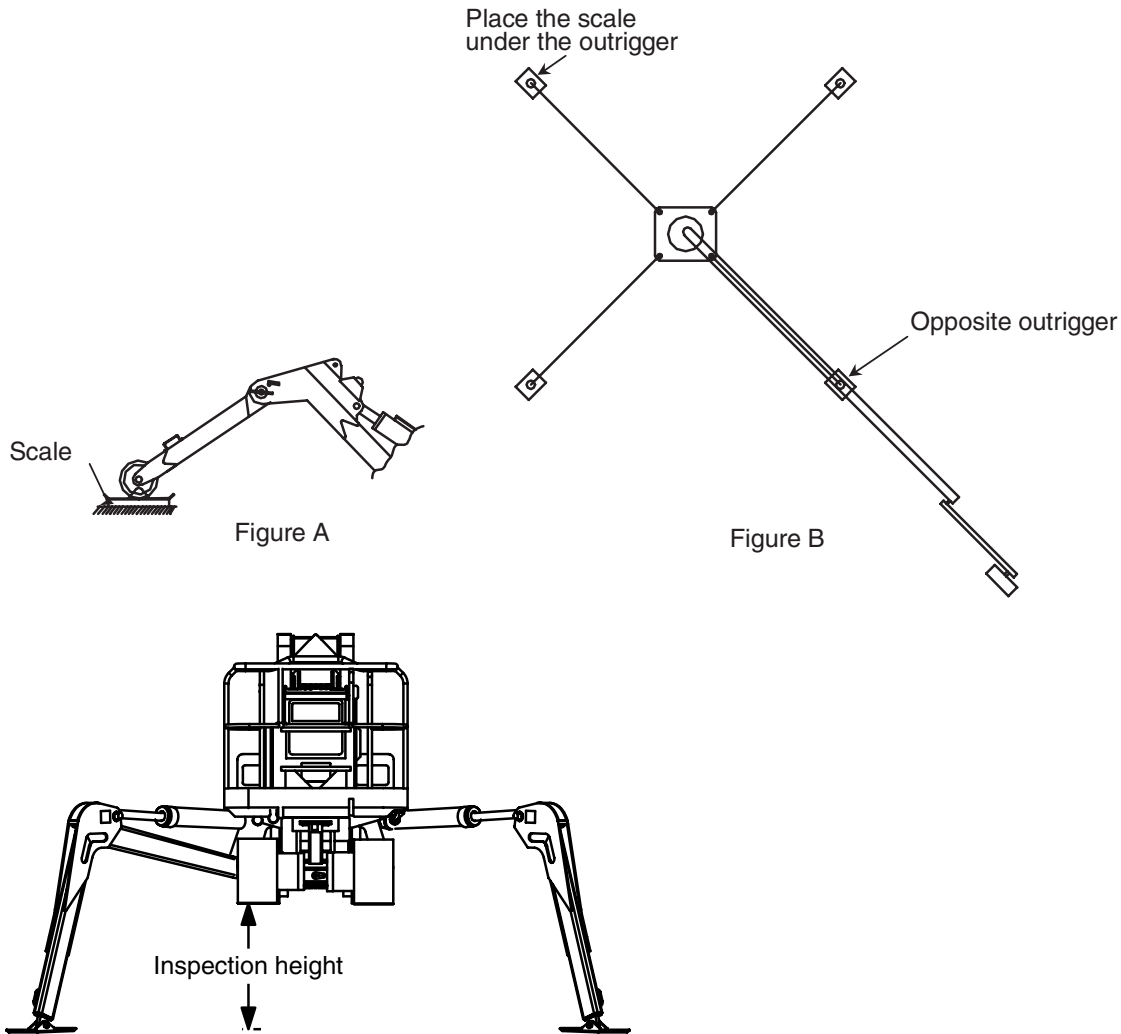

Place the scale under one of the outriggers.
See figure A.
The outriggers must be in standard position.

Raise the platform to inspection height 600 mm telescope out over the opposite outrigger until the red lights at the outrigger at the scale comes on.
(See figure B)
See table to see accurate allowed weight

WARNING

If the **red** lights do not light up or the scale does not show allowed weight according to table column A, call an authorized service centre immediately.

Failure in the safety system can result in injury or death.

Retract the Telescopes until the light on the outrigger at the scale turns off. The scale may maximum show allowed weight according to table when the **red** light turns off.

Repeat this procedure on all 4 outriggers.

WARNING

If the scale shows more than maximum allowed weight according to table column B, call an authorized service centre immediately.

Failure in the safety system can result in injury or death.

Scale for model	A Kg for lights to light up	B Maximum weight when light turns off
FS230 /75	225 kg / 495 lbs	340 kg / 748 lbs
FS230C /75T	x	x
FS290 /95	295 kg/325 kg* / 649/715* lbs	450 kg/525 kg* / 990/1155* lbs
FS290C /95T	325 kg / 715 lbs	525 kg / 1155 lbs
FS320 /105	325 kg / 715 lbs	525 kg / 1155 lbs
FS320C /105T	325 kg / 715 lbs	525 kg / 1155 lbs
FS370 / 121	750 kg / 1650 lbs	1150 kg / 2530 lbs
FS370C /121T	825 kg / 1815 lbs	1200 kg / 2640 lbs
FS420 / 138	800 kg / 1760 lbs	1200 kg / 2640 lbs
FS420C /138T	825 kg / 1815 lbs	1200 kg / 2640 lbs

**Hatz Diesel or Honda generator + 4 extra batteries*

10.6 Spare parts modification

Spare parts are listed in separate spare parts catalogue.

Do not repair with unauthorised components.
Do not make any modifications without prior written approval.

10.7 Tightening of the crawler belts Platforms with 1 set of belts

Tighten the crawler belts once a week with lubrication grease (Type Texaco Multifak EP-2).
Check the adjustment by the nut for the tension roller.

1. Dismount the cover over the grease nipple. (1 nipple on each side of the platform).



Fig. 66 The nut for the tension roller is placed here

2. Tighten the tension roller by a grease gun



Fig. 67 Grease gun on grease nipple for the tension roller



Fig. 68 Nut – Crawler belts NOT tightened

3. When the crawler belts are tightened correctly, there must be a distance between nut and the rear plate of app. 0,5-1mm.

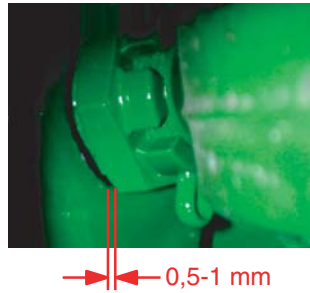

Fig. 69 Nut – Crawler belts tightened

4. It can be difficult to see the nut. Use a mirror.



Fig. 70 Placement of mirror

10.8 Tightening of the crawler belts Platforms with 2 set of belts

Tighten the crawler belts once a week with lubrication grease (Type Texaco Multifak EP-2). Check the adjustment by the nut for the tension roller.

1. Dismount the covers over the grease nipple. (2 nipples on each side of the platform).



Fig. 66a The nipples for the tension roller is placed here

2. Tighten the tension roller by a grease gun equipped with a pressure gauge. Use the adapter between the nipple and the grease gun. There is one type of adapter for the front belts and another type for the rear belts.



Fig. 67a Grease gun on grease nipple with adaptor for the tension roller



Fig. 68a Pressure gauge on Grease gun

3. When the crawler belts are tightened correctly the pressure must show max. 150 bar in the front belts and max. 200 bar in the rear belts

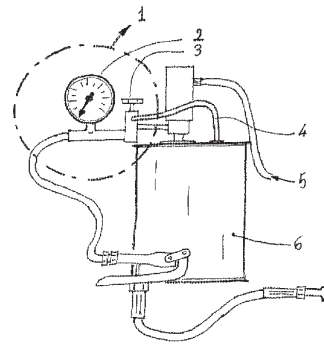
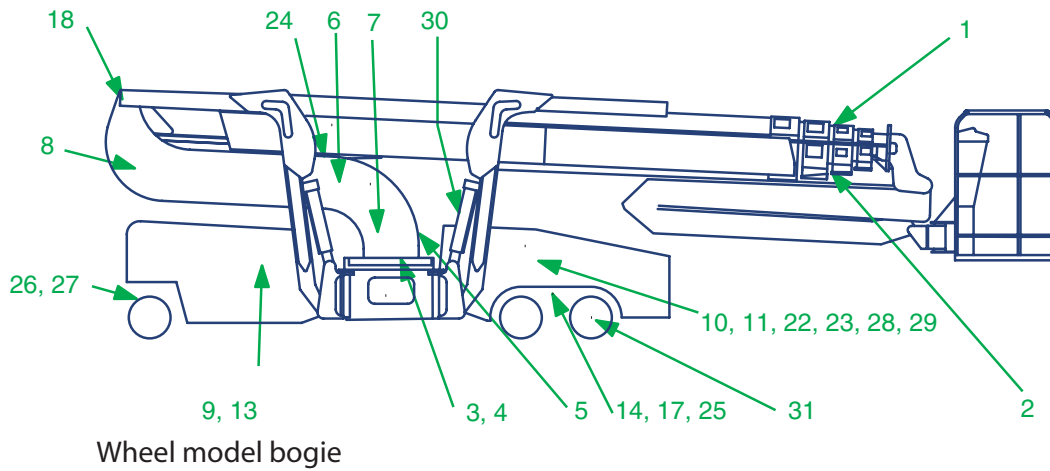
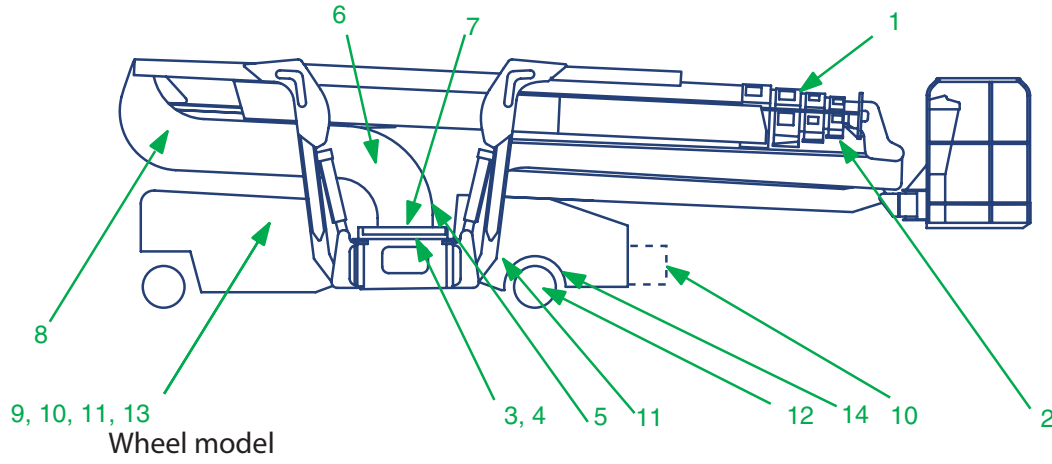

Fig. 69a Track tightening kit

- | | |
|---|----------------------|
| 1 | Track tightening kit |
| 2 | Pressure gauge |
| 3 | Pressure regulator |
| 4 | Grease drain |
| 5 | Compressed air |
| 6 | Grease container |

10.8 Lubrication diagram



Lubrication diagram

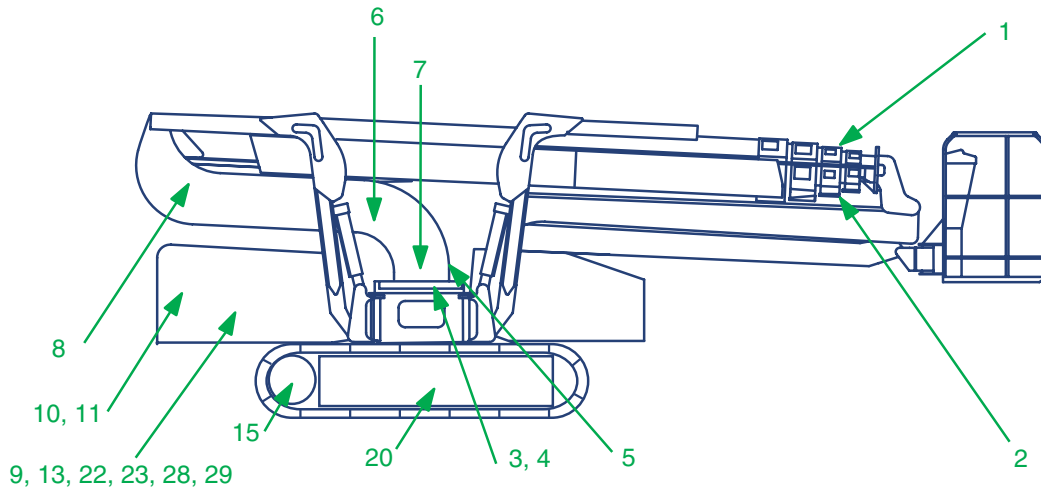

Crawler model

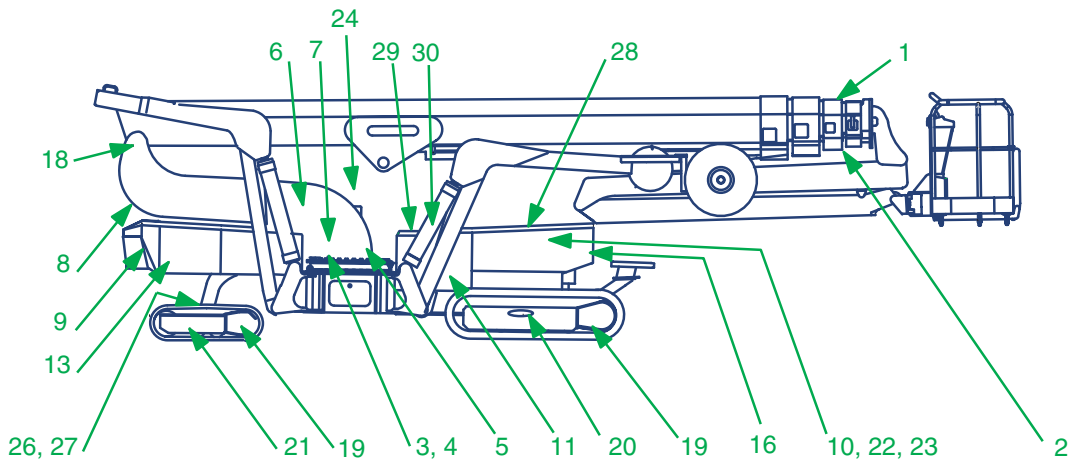

Crawler model double track



Spot:	Place for servicing	No. of spots	Type of maintenance	Lubrication etc.	Quantity/ liters	Service interval/ hours
1	Telescopes	2-5	Grease	Texaco Multifak EP2		Once a year
2	Chains in main boom	2-12 chains	Lubrication spray	Würth 0890 105 51-B		Once a year
3	Race ring	2-4	Grease	Texaco Multifak EP2		50
4	Race ring teeth	All	Grease	Texaco Multifak EP2		50
5	Swivel gear	1	Oil	Texaco geartex EP-C SAE 80W/90	0,75	*
6	Hydraulic oil in tank	1?	Oil	Texaco HDZ 32Rando	50-110	**
7	Suction strainer in oil tank	1				**
8	Return filter	1				Once a year
9	Pressure filter	1				Once a year
10	Fuel tank (option)		***	***		Daily
11	Oil for engine (option)		***	***		***
12	Rear wheel brake	2	Oil	Texaco ursa Super SAE10	0,075L/gear	*
13	Balance filter		Change			Once a year
14	Guides for gauge	2	Grease	Texaco Multifak EP2		50
15	Gear for crawler tracks	2	Oil	Texaco geartex EP-C SAE 80W/90		****
16	Return filter for crawler tracks	1				Yearly
17	Bogie	2	Grease	Texaco Multifak EP2		50
18	Axle for main boom	2	Grease	Texaco Multifak EP2		50
19	Track gear	4	Oil	Texaco Meropa 150	0,5	****
20	Tightening crawler tracks	2	Grease	Texaco Multifak EP2		Weekly
21	Tightening crawler tracks front	2	Grease	Texaco Multifak EP2		Weekly
22	Fuel filter	1	***	***	***	***
23	Oil filter	1	***	***	***	***
24	Main boom cylinder	2	Grease	Texaco Multifak EP2		50
25	Gauge change cylinder	4	Grease	Texaco Multifak EP2		50
26	Front wheel bearing	2	Grease	Texaco Multifak EP2		50
27	Front wheel cylinder	3	Grease	Texaco Multifak EP2		50
28	Air filter	1	***	***	***	***
29	Cooling liquid	1	***	***	***	***
30	Axle for outrigger	8	Grease	Texaco Multifak EP2		50
31	Rear wheel gear	2	Oil	Texaco geartex EP-C SAE 80W/90	0,5l/gear	*

* = Once a year check the oil and refill as required. Replace the oil when it is needed.

** = Replace as required

*** = For lubrication and maintenance of engine and/or extra equipment, please follow the instructions in the Maintenance- or Operators Manual specified for those parts.

**** = First time after 500 hours, after this for every 1000 hours or once a year.

(1) = See section 10.7

Appendix

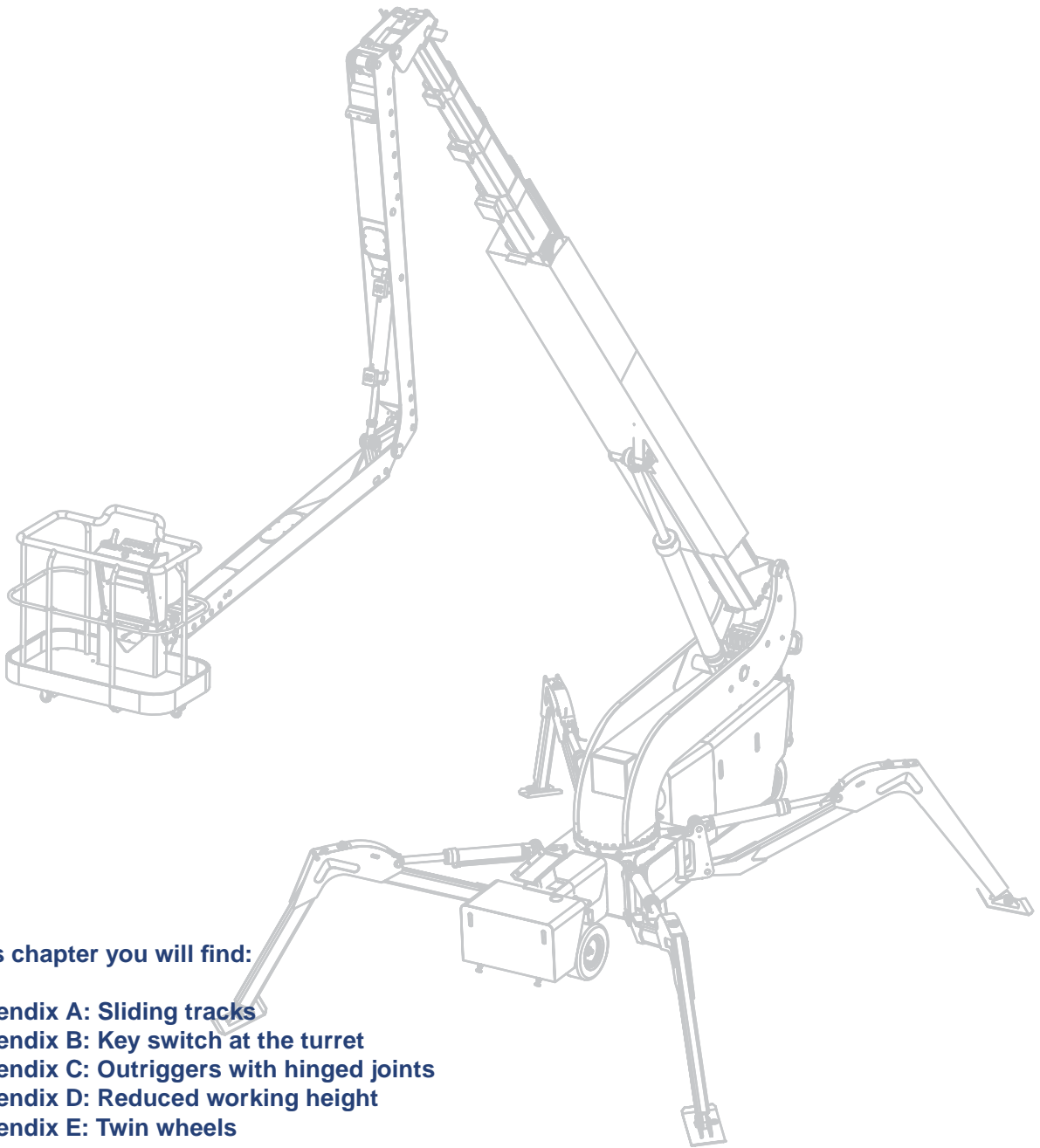

In this chapter you will find:

- **Appendix A: Sliding tracks**
- **Appendix B: Key switch at the turret**
- **Appendix C: Outriggers with hinged joints**
- **Appendix D: Reduced working height**
- **Appendix E: Twin wheels**

Appendix A: Sliding tracks for the outriggers on the Platform (Option).

The platform can optionally be equipped with sliding tracks for the outriggers to protect sensible surfaces against marks and scratches.

The sliding tracks may ONLY be mounted, when the outriggers are turned away from the chassis and secured in position, **green**, **orange** or **yellow**.

CAUTION

Mounting of the sliding tracks with the outriggers in stowed position (Red) can cause structural damage to the platform.

1. Turn the outriggers away from the platform.
2. Secure the outriggers to the chassis frame in position **green**, **orange** or **yellow** and secure the outriggers with the locking bolt.
3. Mount the outrigger footplates according to the operator's manual.
4. Mount the sliding tracks at the outrigger footplates by hand.
5. Lower the outriggers to the ground according to operator's manual. The outriggers will now slide at the surface.
6. When the platform has to be moved, lift the outriggers from the ground, according to the operators manual, so that the sliding track no longer have contact with the ground. Move the platform and lower the outriggers.



Sliding track mounted at the outriggerAppendix B: Key switch at the turret

Appendix B: Key switch at the turret for operating the chassis without main boom in cradle (Option)

WARNING

Never use this function with wheels in narrow position, always make sure that rear wheels are set in maximum wide position before engaging this feature. Never raise the boom above 2,4 m. in this mode, measured from floor to end of main boom.

Always use maximum care when driving the unit in this position and only use where absolutely necessary. As soon as surroundings permit driving the lift in normal position (secured in the cradle) lower the main boom as per below instructions.

Always take basket off before switching to this mode.

Never work, place or put anybody or anything in the basket in this mode, this is strictly a transportation mode to pass obstacles on the floor that not otherwise can be passed.

Key-switch 1 – Driving the platform with the main boom in raised position.

1. Activate the electrical emergency pump next to the main switch
2. Move the main boom up by the emergency valves, according to the instructions about emergency operation of the main boom in the operator's manual.
3. Turn the key-switch (1) at the turret to the right.. It is now possible to drive the platform with the main boom in raised position.

WARNING

Driving the platform with the main boom in raised position is only allowed on horizontal surface. Drive slowly and pay attention to the balance of the platform. Driving the platform on non-horizontal surfaces, can cause the platform to turn over and result in personnel and/or material injury or death.

4. Whenever possible drive the platform with the main boom in stowed position (in the cradle). Lower the main boom by the emergency lowering valves, according to the instructions about emergency operation of the main boom in the operator's manual.
5. Turn the key-switch (1) at the turret to the left and remove the key, store key in a safe place.

WARNING

Do NOT use any platform functions, when the key-switch is turned to the right.

This is a feature that requires maximum care, as the lift is very unstable in this mode, and can tip over if handled incorrectly.



Appendix C: Outriggers with hinged joints. (Option).

1. Loosen the hinged joint so the teeth are fully apart, (notice the small hinged safety handle, which prevents the hinged joint from loosening when tightened), and check that the lower part of the outrigger hangs freely.
2. Open/turn the lower part of each outrigger, at least to the standard position, and tighten the hinged joint fully by the hand wheel. Turn the small safety handle into position between the two plates of each of the upper and lower part of the outrigger, to secure the hinged joint against loosening/opening.

Marking for optimized position of hinged joint at the outrigger.



Hinged joint in optimized position

Marking for standard position of hinged joint at the outrigger

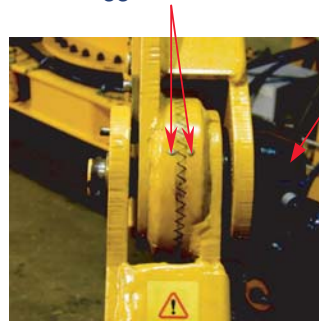

Hinged joint in standard position



Safety handle – Open
Unsafe!



Safety handle – closed.
Safe!

Appendix D: Reduced working height (Option)

Turnable key-switch – Reduction of the working height.

If it is necessary to reduce the working height. Turn the key-switch (2) at the turret to the right and remove the key.

The working height of the platform is now reduced.

To change the working height to the original working height, place the key in the turnable key-switch and turn the key to the left.



Appendix E: Twin wheels

Important!

Outriggers may NOT be placed in narrow position at the rear end if twin wheels are mounted.

Outriggers will collide with the wheels and cause damage to them.

